

# National Cooperative Highway Research Program

# RESEARCH RESULTS DIGEST

November 1998—Number 232

Subject Area: IIC Bridges, Other Structures,  
and Hydraulics and Hydrology

Responsible Senior Program Officer: Edward T. Harrigan

## Report on the 1997 Scanning Review of Asian Bridge Structures

*This digest summarizes the findings from NCHRP Project 20-36, "Highway Research and Technology—International Information Sharing," conducted by a scanning review team of representatives from U.S. federal, state, and private sector agencies. This digest was prepared by Henry G. Russell, Report Facilitator for the review.*

### SUMMARY

This digest describes the findings of an international scanning tour undertaken to obtain a broad overview of bridge design, materials technology, construction procedures, and maintenance practices in Asia. The scanning team focused on identifying technological developments in Asia that have the potential for application in the United States. In addition, the team shared information with their international counterparts on U.S. practices in highway bridge construction, maintenance, and management to promote international exchange and cooperation.

The scanning tour concentrated on the following topics:

- Design standards, codes, and specifications;
- Design and construction practices;
- Materials, fabrication, and joining techniques;
- Bridge protection strategies;
- Inspection and rehabilitation practices;
- Programming and management practices; and
- Innovations.

The review was performed by an 11-member team representing several of the states, the Federal Highway Administration (FHWA), American As-

sociation of State Highway and Transportation Officials (AASHTO), and National Cooperative Highway Research Program (NCHRP). The scanning tour took place from September 12 through September 28, 1997, and involved visits to Japan, South Korea, and Taiwan.

In Japan, the team met with representatives of the Honshu-Shikoku Bridge Authority (HSBA), Public Works Research Institute (PWRI), Japan Highway Public Corporation (JH), Metropolitan Expressway Public Corporation (MEPC), Tokyo Institute of Technology, Nippon Steel Corporation, and Yokogawa Bridge Corporation. In South Korea, the team met with representatives of the Korea Highway Corporation (KHC). In Taiwan, the team met with representatives of the Taiwan Area National Freeway Bureau and the Taiwan Area National Expressway Engineering Bureau of the Ministry of Transportation and Communications. In all three countries, site visits were made to major bridges.

On the basis of the observations made during the scanning review, the team developed a list of 30 topics for possible application in the United States. The list was then divided into 6 high-priority topics, 7 medium-priority topics, and 17 other topics for consideration at a later date.

**CONTENTS****Summary, 1**

- High-Priority Topics, 3
- Medium-Priority Topics, 3
- Other Topics, 3

**Introduction, 3**

- Purpose, 3
- Sponsoring Organizations, 4
- Team Members, 4
- Metric Equivalents, 4
- Organizations and Site Visits, 4

**Summary of Recommended Technologies, 13**

- High-Priority Topics, 13
- Medium-Priority Topics, 14
- Other Topics, 15

**Design Standards, Codes, and Specifications, 18**

- Japan, 18
- South Korea, 18
- Taiwan, 19
- Recommendations on Design Standards, Codes, and Specifications, 19

**Design and Construction Practices, 19**

- Japan, 19
- South Korea, 24
- Taiwan, 25
- Recommendations on Design and Construction Practices, 27

**Materials, Fabrication and Joining Techniques, 27**

- Japan, 27
- South Korea, 32
- Taiwan, 33
- Recommendations on Materials, Fabrication and Joining Techniques, 33

**Bridge Protection Strategies, 33**

- Japan, 33
- South Korea, 35
- Taiwan, 35
- Recommendations on Bridge Protection Strategies, 37

**Inspection and Rehabilitation Practices, 37**

- Japan, 37
- South Korea, 38
- Taiwan, 38
- Recommendations on Inspection and Rehabilitation Practices, 38

**Programming and Management Practices, 39**

- Japan, 39
- South Korea, 39
- Taiwan, 39

**Other Innovations, 39**

- Recommendations on Other Innovations, 40

**Appendix A Amplifying Questions, 40****Appendix B Material Reviewed, 41****Appendix C Itinerary, 42****Appendix D Team Members, 43****Appendix E Acronyms, 43****Appendix F Selected Figure from CATS Brochure, 44****Acknowledgments, 45**

### High-Priority Topics

The following topics were identified as high-priority:

- Dimple pipe for exterior of stay cables.
- Nonsegregating flowable concretes.
- A computerized assembly and test system (CATS) for steel components.
- Nonmetallic removable back-up bars for one-sided welding.
- Dry air injection system for corrosion protection of cables.
- Special paint primer.

### Medium-Priority Topics

The following seven topics were identified as medium priority:

- Balanced cantilever construction with alternate segments offset by 1/2-segment length.
- Full cantilever erection for end spans of balanced cantilever bridges.
- Nonseparating (desegregating) tremie concretes.
- 19-wire prestressing strands.
- Wrapping wire with interlocking cross section.
- Flame or thermal spray metallizing.
- Translation of relevant sections of the HSBA specifications into English.

### Other Topics

The following 17 topics were identified for consideration at a later date:

- Research on punching shear failure.
- Bolted connections for earthquake resistance.
- Mechanical damping devices to control vibrations of steel towers.
- Forced vibration tests on completed bridges.
- Special railway expansion joints for flexible long-span bridges.
- Pneumatic caissons with remote control equipment for underwater construction.
- Slurry-wall construction for tower foundations.
- High-strength silicon steel wire.
- Steels containing a higher percentage of nickel.
- Vibration damping steel plates.
- Thermo-mechanical control processing or similar technology.
- Truss elements that taper to I-sections at the end connections.
- HSBA paint system.

- Asphalt overlays for orthotropic steel decks.
- Built-in access and utilities for bridge inspection and maintenance.
- A repair robot for use in inaccessible areas.
- Public relations programs for major projects.

The team recognizes that some of the technologies encompassed by the topics listed above are already used to a limited extent in the United States. The observation of their use in other countries supports the viability of the technology.

## INTRODUCTION

### Purpose

The purpose of the scanning tour was to conduct a broad overview of bridge design, materials technology, construction procedures and maintenance practices in Asia. The focus of the team's review was to identify technological developments in Asia that have the potential for application in the United States. In addition, the team shared information with their international counterparts on U.S practices in highway bridge construction, maintenance, and management to promote international exchange and cooperation.

The team's review concentrated on the following general topics of interest:

- Design standards, codes, and specifications.
- Design and construction practices.
- Materials, fabrication and joining techniques.
- Bridge protection strategies.
- Inspection and rehabilitation practices.
- Programming and management practices.
- Innovations.

A separate section of this digest is devoted to each of the above topics. Recommendations on practices and technologies that are unknown or rarely used in the United States are included at the end of each major section. The recommended practices and technologies are listed along with recommendations for their implementation.

Prior to the trip, a list of amplifying questions on the above topics was developed by the team and submitted to the organizations that were visited. The list of questions served to define the interests of the scanning tour and provided a basis for discussion at the formal meetings. The list of questions is included in Appendix A. In addition to the discussions held during the tour, the team was provided with numerous documents and references to other documents for further information. A list of documents reviewed for the preparation of this report is given in Appendix B. The itinerary for the scanning tour is contained in Appendix C.

## Sponsoring Organizations

The technology scanning review of Asian bridges was conducted under the auspices of FHWA's Office of International Programs and NCHRP in cooperation with AASHTO. The American Road and Transportation Builders' Association (ARTBA), the National Steel Bridge Alliance (NSBA) and the Portland Cement Association (PCA) provided input in the initial planning stages.

## Team Members

The team members, along with the agencies that they represented, are listed below.

<i>Name</i>	<i>Representing</i>	<i>Organization</i>
Charles L. Chambers (Co-Chair)	FHWA	FHWA, Washington, DC
James Siebels (Co-Chair)	AASHTO	Colorado DOT
Ralph E. Anderson	AASHTO	Illinois DOT
John Formosa	FHWA	FHWA, Albany, NY
John M. Hooks	FHWA	FHWA, Washington, DC
John M. Kulicki	NCHRP/ ARTBA	Modjeski and Masters, Inc.
Jerry L. Potter	AASHTO	Florida DOT
Henry G. Russell (Report Facilitator)	NCHRP	Henry G. Russell, Inc.
James E. Sothen	AASHTO	West Virginia Division of Highways
William J. Wright	FHWA	FHWA, McLean, VA
George Y. Yamamoto (Japan Only)	AASHTO	California DOT

Appendix D provides biographical information on the team members.

## Metric Equivalents

The primary units used in this report are based on the International System of Units (SI). However, since Japan, South Korea, and Taiwan still use the kilogram force system, some of the reported information has been retained in the original units to provide consistency with the original documentation.

## Organizations and Site Visits

This section contains background information on the organizations visited and a summary of each site visit. Further details of relevant observations and information learned during team meetings and specific recommendations are given in subsequent sections.

### *Japan*

In Japan, the team met with representatives of HSBA, PWRI, JH, MEPC, Tokyo Institute of Technology, Nippon Steel Corporation, and Yokogawa Bridge Corporation. Specific site visits were made to the Akashi-Kaikyo Bridge, Kurushima Bridges, and Tatara Bridge. The team also observed and heard a description of the Seto-Ohashi Bridges. Visits were made to the Nippon Steel Corporation (Kimitsu Works) and Yokogawa Bridge Corporation (Chiba Plant).

Japan has at least four organizations responsible for the national highway system. JH is responsible for the system that is not under the jurisdiction of other authorities. Some of the major bridges of JH are listed in Table 1. These bridges were not visited by the team. MEPC is responsible for 248 km (154 mi) of expressway in the Tokyo metropolitan area. The Hanshin Expressway Corporation is respon-

**TABLE 1 Major bridges of the Japan Highway Public Corporation**

Bridge Name	Bridge Type	Length		Maximum Span		Year Built
		m	ft	m	ft	
Beppu Myoban	Concrete Arch	411	1,348	235	771	1989
Kanmon	Suspension	1,068	3,504	712	2,336	1973
Meikou 3	Cable-Stayed	1,170	3,839	590	1,936	1998
Odawara Blue Way	Extradosed Prestressed Concrete	270	886	120	394	1994
Tomie Asigara	Concrete Cable-Stayed	785	2,575	185	607	1991
Okaya Viaduct	Continuous Prestressed Concrete Rigid Frame	1,489	4,885	148	486	1986
Katashina River	Steel Truss	1,034	3,392	169	554	1985
Ueda Roman	Solid Spandrel and Open Arch	715	2,346	54	177	1995
Horonai River	Steel Plate Girder - Prestressed Concrete Slab	107	351	53	174	1996

**TABLE 2 Major bridges of HSBA**

Route	Bridge	Type	Spans <sup>(1)</sup> m
Kobe-Naruto	Akashi-Kaikyo <sup>(2,3)</sup>	Suspension	960, 1,990, 960
	Ohnaruto	Suspension	330, 876, 330
Kojima-Sakaide	Shimotsui-Seto	Suspension	230, 940, 230
	Hitsuishijima	Cable-Stayed	185, 420, 185
	Iwakurojima	Cable-Stayed	185, 420, 185
	Kita Bisan-Seto	Suspension	274, 990, 274
	Minami-Bisan-Seto	Suspension	274, 1,100, 274
Onomichi-Imabari	Shin Onomichi	Cable-Stayed	85, 215, 85
	Onomichi	Cable-Stayed	85, 215, 85
	Innoshima	Suspension	256, 770, 250
	Ikuchi	Cable-Stayed	150, 490, 150
	Tatara <sup>(2,4)</sup>	Cable-Stayed	270, 890, 320
	Ohmishima	Arch	297
	Hakata-Ohshima	Suspension	140, 560, 140
	Kurushima 1 <sup>(2)</sup>	Suspension	190, 600, 170
	Kurushima 2	Suspension	250, 1,020, 245
Kurushima 3	Suspension	260, 1,030, 280	

1. Major spans only
2. Bridges visited by team
3. World's longest suspension bridge
4. World's longest cable-stayed bridge

sible for the expressway system in the Osaka and Kobe metropolitan area. HSBA is responsible for bridges between the islands of Honshu and Shikoku.

HSBA was founded in 1970 to oversee the construction and operation of the toll highways and railways that link the islands of Honshu and Shikoku across the Seto Inland Sea. The three links are known as the Kobe-Naruto Route, Kojima-Sakaide Route and Onomichi-Imabari Route. The route names are based on the cities at the end of each link in Honshu and Shikoku. A listing of the major bridges on the three routes is given in Table 2. In addition, there are numerous approach structures and access ramps.

The Kobe-Naruto Route is the most eastern crossing and is partly complete. The route features a six-lane highway. The crossing includes two suspension bridges—the Akashi-Kaikyo Bridge and the Ohnaruto Bridge. The Akashi-Kaikyo Bridge was almost complete at the time of the team's visit. The Ohnaruto Bridge was open to traffic.

The Kojima-Sakaide Route is the central crossing and was completed in 1988. The crossing includes a suspension bridge (Shimotsui-Seto Bridge), two cable-stayed bridges (Hitsuishijima and Iwakurojima Bridges shown in Figure 1), and two suspension bridges (Kita Bisan-Seto and Minami Bisan-Seto Bridges shown in Figure 2). The upper deck of these bridges is used for a four-lane highway and the lower deck for a double-track railway. The bridges on the Kojima-Sakaide Route are known as the Seto-Ohashi Bridges.

The Onomichi-Imabari Route is the most western crossing and is partly complete. The route features a four-lane

highway. From north to south, it includes two parallel cable-stayed bridges (Onomichi and Shin Onomichi Bridges), a suspension bridge (Innoshima Bridge), a cable-stayed bridge (Ikuchi Bridge), a cable-stayed bridge (Tatara Bridge), an arch bridge (Ohmishima Bridge), a suspension bridge (Hakata-Ohshima Bridge), and three continuous suspension bridges (Kurushima Bridges). The route is scheduled for completion in 1999.

The Akashi-Kaikyo Bridge, shown in Figure 3, is a 3,910-m (12,828-ft)-long, three-span suspension bridge with span lengths of 960, 1,990, and 960 m (3,150,



Figure 1. Cable-stayed bridges on the Kojima-Sakaide Route.



Figure 2. Suspension bridges on the Kojima-Sakaide Route (Photo by HSBA).

6,529, and 3,150 ft). The steel towers have a height of 283 m (928 ft) above the top of their foundations. The superstructure consists of a double-deck two-hinged steel stiffening truss. Six lanes of highway traffic are carried on an orthotropic steel deck on the upper level. The lower level carries utilities, an access road, and inspection galleries. Total width of the bridge is 35.5 m (116 ft). The bridge tower foundations were constructed in a water depth of about 60 m (197 ft). The maximum water depth beneath the bridge is about 110 m (360 ft) and the maximum current speed is 4.5 m/s (15 ft/s). The Akashi-Kaikyo bridge opened to traffic in April, 1998, and is the world's longest suspension bridge.

The uniqueness of the structure resulted in the use of several innovative design and construction features. These features include the following:



Figure 3. Akashi-Kaikyo Bridge (Photo by HSBA).

- Design life of 100 years.
- Design wind speeds of 60 m/s (134 mph) for the stiffening girder and 67 m/s (150 mph) for the towers.
- A lower factor of safety for the design tensile stress of the main cables because dead load forces dominate the design more than in a conventional bridge.
- Wind tunnel testing of a 1:100 scale model with a length of 40 m (131 ft) verified that the bridge could withstand wind speeds of 80 m/s (179 mph).
- Design for an earthquake magnitude of 8.5 on the Richter scale.
- Double-walled steel caissons for the outer liner of the pier foundations.
- Special nonseparating or desegregating concrete with a water-soluble high molecular compound and high-range water-reducer for the underwater concrete.
- Self-levelling highly flowable nonsegregating concrete.
- Roller-compacted concrete for the cable anchorage foundations.
- Slits in the anchor blocks to help dissipate the heat of hydration.
- Riprap around the tower foundations to protect from scour.
- High-strength poly-aramid fiber rope as the pilot rope.
- Two main cables, each consisting of 290 strands of 127 5.23-mm (0.21-in.) diameter wires for a cable diameter of 1.122 m (44 in.).
- High tensile strength steel with a tensile strength of 180 kgf/mm<sup>2</sup> (256 ksi) in the cables.
- Noncircular cable cross section at tower saddles.
- Collision protection system for both piers and ships.
- Vibration tests of steel towers.
- Erection of the superstructure beginning at the piers and anchor blocks.
- Orthotropic steel deck with asphalt overlay.
- Open grating in the center and edges of the deck, as shown in Figure 4, and vertical stabilizers at the center for wind vibration control.
- Truss elements that taper to I-sections at end connections.
- Special expansion joints to accommodate large movements.
- Fluoro-polymer and polyurethane paint systems for protection of the steel.
- Special exterior wall surface finishes to minimize radar interference.
- Selection of paint color to harmonize with the local environment.
- Built-in travellers and lifts for bridge inspection and maintenance.
- Use of dry air system to reduce humidity inside the cables.
- Air conditioning of the anchor block houses to reduce humidity.





Figure 4. Vents to equalize air pressure on the Akashi-Kaikyo Bridge.

The Kurushima Bridges consist of three continuous suspension bridges with lengths of 960, 1,515, and 1,570 m (3,150, 4,970, and 5,151 ft). The main spans are 600, 1,020, and 1,030 m (1,969, 3,346, and 3,379 ft) long. The tallest towers have a height of 184 m (604 ft) above the top of their foundations. As shown in Figure 5, all three bridges were under construction during the visit. The target completion date is 1999. Kurushima 1, which was visited by the team, is shown in Figure 6. These bridges contain the following features:

- Basic wind speed of 40 m/sec (89 ft/sec) at 10 m (33 ft) height and a design wind speed of 51 m/s (114 mph) for Kurushima 1 and 53 m/s (119 mph) for Kurushima 2 and 3.
- Design for earthquake magnitude of 8.5 on the Richter scale.
- Poly-aramid fiber rope as the pilot rope.
- Main cables composed of strands made from 127 galvanized steel wires approximately 5 mm (0.20 in.) in diameter with a tensile strength of 180 kgf/mm<sup>2</sup> (256 ksi). The number of strands per cable are 44 for Kurushima 1 and 102 for Kurushima 2 and 3.
- Erection sequence starting at midspan using hoists mounted on the main cables.
- Self-positioning barge for transportation and positioning of deck sections below the bridge.
- Interlocking wire-wrapping system around the main cables.
- Stiffening girders consisting of a box girder section with orthotropic deck.
- Asphalt wearing surface.
- Fluoro-polymer and polyurethane paint systems.
- Use of dry air system to reduce humidity inside the cables.

The Tatara Bridge, shown in Figure 7, is a cable-stayed bridge with span lengths of 270, 890, and 320 m (886, 2,920,



Figure 5. Kurushima Bridges under construction.

and 1,040 ft). Total width of the superstructure is 30.6 m (100 ft). The towers have a height of 220 m (722 ft) above their foundations. The bridge was originally designed as a suspension bridge but was later changed to a cable-stayed structure to avoid excessive earthworks that would have been required for an abutment. When completed, Tatara will be the world's longest cable-stayed bridge. Features of the bridge include the following:

- Inverted Y-shaped steel towers with a slit in the upper two shafts. The basic shape was selected for aesthetic reasons. Details of the cross section were based on wind tunnel tests.
- Two planes of cables arranged in a fan pattern.
- Prefabricated stay cables anchored in the pylon. Each cable consists of galvanized steel wires and is coated with polyethylene in the prefabrication shop.
- Use of dimpled surface on the cable coating to reduce wind-induced oscillations.
- Use of steel girder with orthotropic steel deck for the superstructure of the main spans and prestressed con-



Figure 6. Kurushima 1 under construction.



Figure 7. Tatara Bridge under construction

crete for the side spans between the intermediate and end piers. Concrete was used to balance the weight of the structure because the length of the main span creates a dead load imbalance.

- Use of floating crane to erect deck segments.

Nippon Steel Corporation is Japan's largest producer of crude steel and in 1996 had a total crude steel production of 25.3 million metric tons (27.8 million short tons). The corporation has eight blast furnaces. Three of the furnaces are located at the Kimitsu Works, which was visited by the team. The Kimitsu Works is situated near Tokyo on a site with a total area of 10 million m<sup>2</sup> (3.9 mi<sup>2</sup>). Annual crude steel production in 1996 was 8.2 million metric tons (9.0 million short tons). The plant employs approximately 4,100 people. It was reported that 2 to 3 percent of their total budget is allocated for research on new applications. Some of the research involved projects that would benefit public bridge owners. The team visited the Steel Structures Development Center of the Research and Engineering Center, Blast Furnace No. 4, which has the capability of producing 11,000 tons per day, and associated steel production facilities.

In general, the site visit to the Nippon Steel Corporation's Kimitsu Works revealed similar technology to major steel mills in the United States. The steel making operation began with a blast furnace to produce pig iron, a basic oxygen furnace to melt the steel, and a continuous caster to produce solid slabs. The rolling mill was also similar to U.S. practice, except for the addition of thermo-mechanical control processing (TMCP) equipment. The Kimitsu Works can produce steel plates with thicknesses from 4.5 to 200 mm (0.2 to 7.9 in.), widths from 0.9 to 4.5 m (3.0 to 14.8 ft), and lengths from 3 to 25 m (9.8 to 82.0 ft). It is larger than the plate-producing mills in the United States.

The following items were noted during the visit:

- Research on the use of bolted beam-column connections for rectangular column members to improve their earthquake resistance. Full-scale tests of connections

under real-time dynamic displacements were being conducted.

- Research on the use of circular external rings to limit buckling of tubular columns. Tests under static and pseudo-dynamic loads were being conducted on reduced-scale members to identify retrofit methods.
- Research on concrete-filled steel tubes to limit damage caused by earthquake loading.
- Vacuum degassing for all steels used in bridge construction.
- Thermo-mechanical control processing.
- Continuous casting of steel.

The Yokogawa Bridge Corporation is one of Japan's leading fabricators and erectors of steel structures for bridges, frames, and towers. The company was established in 1907 and has plants in Osaka and Chiba. The Chiba Plant was established in 1969 and occupies a land area of 132,146 m<sup>2</sup> (32.7 acres). Production capacity is 4,000-5,000 metric tons/month (4,400 to 5,510 short tons/month). Components weighing as much as 200 metric tons (220 short tons) can be handled. It was indicated that the plant is a typical Japanese plant. It is qualified to construct major bridges in Japan and has the AISC Level III certification for major bridges in the United States. The plant has fabricated components for several bridges owned by HSBA and for bridges in the United States. The company also performs a large amount of work for steel buildings.

In general, the fabrication practices at the Chiba Plant were not significantly different from many operations in the United States. Submerged arc welding (SAW) appeared to be the dominant practice as is common in the United States. The same was true of many of the basic cutting and fit-up operations.

The following items were noted during the visit:

- Implementation of CADD/CAM technology.
- Great emphasis on quality control of layout and tolerances.
- Use of high heat input welding.
- Three-wire welding for bridges.
- Electro slag/electro gas welding.
- Nonmetallic removable back-up bars for one-sided welding.
- Computerized assembling test system.

#### South Korea

In South Korea, the team met primarily with representatives of the Korea Highway Corporation (KHC). Representatives of the Korea Infrastructure Safety & Technology Corporation and Daiwoo Engineering Company were present during some of the meetings or site visits. Visits were made to the Seo-Hae Grand Bridge, the Kimp'o Grand Bridge, the Youngjong Bridge, and the POSCO Center in Seoul.



In South Korea, the Ministry of Construction and Transportation (MOCT) is responsible for administration, planning, design, construction, and maintenance of all public roads. MOCT has the authority to develop the master plan for highways and to designate and manage national highways, except for the portions located within the jurisdiction of municipalities which are managed by the municipalities. The Bureau of Public Roads (BPR) of MOCT is the government agency responsible for policies related to public roads. All plans prepared by various agencies are reviewed by the BPR. At the end of 1996, the total length of roads in South Korea was 82,342 km (51,165 mi) of which 10,284 km (6,390 mi) have four lanes.

KHC is a government-financed organization formed in 1969. It has responsibility for twenty national expressways with a length of 1,840 km (1,143 mi). KHC plans to construct a grid-shaped expressway system in South Korea. This will double the present system to 3,500 km (2,175 mi) by the year 2004. Longer-range plans call for 6,000 km (3,728 mi) by the year 2020. Currently, KHC has a staff of approximately 5,000.

The Seo-Hae Grand Bridge, currently under construction, is part of the Seo-Hae Coastal Highway that will connect the highly developed areas of Seoul with the west coast. The bridge will cross the Han-Gang River. The overall length of the bridge will be 7.31 km (4.54 mi), which will be the longest bridge in South Korea. The bridge will consist of the following three types of construction:

- A cable-stayed bridge with a length of 990 m (3,248 ft).
- Precast concrete, constant depth, segmental bridges with a length of 5,820 m (19,095 ft).
- Cast-in-place concrete, variable depth, box girder bridges with a length of 500 m (1,640 ft).

The cable-stayed bridge, shown in Figure 8, will have span lengths of 60, 200, 470, 200, and 60 m (197, 656, 1,542,

656, and 197 ft). The main span of 470 m (1,542 ft) will be the longest clear span in South Korea. The height of the two H-shaped pylons will be 182 m (597 ft) above the foundations. The steel segments for the superstructure will be delivered by barge and lifted with a derrick crane. Precast concrete teams will then be installed on the steel segments and concrete placed to form a composite member. The cables will be arranged in two planes with 72 cables per plane. The cables will contain 15.2-mm (0.6-in.)-diameter parallel steel strands. The number of strands per cable will vary from 37 to 91. The strands will be coated with grease or wax on the inside of the anchorage. Cell-type cofferdams are being used for construction of the pylon foundations. This is the first application of its kind in South Korea.

The precast segmental bridges will consist of twin continuous single cell boxes with span lengths of 60 m (197 ft). Each segment will have a width of 15.5 m (50.8 ft), a constant depth of 3.5 m (11.5 ft), and a length of 3 m (9.8 ft) for a total weight of 70 to 80 metric tons (77 to 88 short tons). The segments will be erected using the span-by-span method with a steel launching truss.

The cast-in-place, variable depth, box girder will have span lengths of 85, 165, 165, and 85 m (279, 541, 541, and 279 ft). Segment depth will vary from 3.5 to 9.0 m (11.5 to 29.5 ft). The segments will be erected using the balanced cantilever method. The completed structure will include movable facilities for inspection and maintenance.

The Kimp'o Grand Bridge, shown in Figure 9, will carry the Seoul Metropolitan outer ring road across the Han-Gang River. The bridge has a total length of 3.5 km (2.18 mi) with 2.28 km (1.42 mi) on elevated structure. The elevated portion includes the following types of construction:

- Cast-in-place concrete, constant depth, box girders constructed using a movable formwork system with a total length of 950 m (3,116 ft).



Figure 8. Seo-Hae cable-stayed bridge (Artist rendering courtesy of KHC).



Figure 9. Kimp'o Grand Bridge (Artist rendering courtesy of KHC).

- Cast-in-place concrete, variable depth box girder constructed by the balanced cantilever method with a total length of 930 m (3,051 ft).
- Precast concrete, constant depth, box girders with a total length of 400 m (1,312 ft).

A unique feature of the Kimp'o Grand Bridge is the length of 930 m (3,051 ft) between expansion joints at the end of the variable depth box girder section. Figure 10 shows a photograph of the expansion joint during installation. Modular joints are used with center line splicing of transverse beams. Deck protection is provided by liquid membrane and asphalt overlay. Samples of strand couplers and anchorages were on display at the bridge site.

The Youngjong Bridge is part of the Incheon International Airport Expressway that will connect the new airport to other major highways around Seoul and to the center of Seoul. The expressway is scheduled for completion in 2000. Travel time from the airport to downtown Seoul is expected to be about 45 min. At the time of the team visit, foundations for the bridge piers were under construction.

The Youngjong Bridge will have a total length of 4.42 km (2.75 mi). The main structure, depicted in Figure 11, will be a suspension bridge with span lengths of 125, 300 and 125 m (410, 984 and 410 ft). The two towers will be shaped like a diamond and will have a height of 107 m (351 ft). As a result of the sloping tower legs, the two main cables will have the shape of a traditional Korean roof line. The cables will be self-anchored to the stiffening truss. Cable protection will consist of zinc coating on the individual wires, a galvanized wrapping wire, and paint. The bridge is designed for tides of 10 m (30 ft), a current of 2.5 m/s (5.6 mph), and a wind speed of 40 m/s (89 mph). The superstructure will carry road traffic on the upper deck and rail traffic on the lower deck. It is reported to be the first bridge in the world to carry a 10-lane expressway and double-track railroad.

The visit to the POSCO Center provided the team with



Figure 10. Installation of expansion joint on Kimp'o Grand Bridge.

the opportunity to review displays about steel production and steel products.

#### Taiwan

In Taiwan, the team met primarily with representatives of the Taiwan Area National Freeway Bureau and the Taiwan Area National Expressway Engineering Bureau of the Ministry of Transportation and Communications (MOTC). Other organizations represented during team meetings included the Office of Science & Technology Advisers of MOTC, Department of Railways & Highways of MOTC, China Engineering Consultants, Inc., T. Y. Lin International, Dywidag Systems International, Kungsing Construction Corporation, National Taiwan University, and National Taiwan University of Science and Technology. Site visits were made to the Kaohsiung-Pingtung (Kao-Ping) River Bridge and numerous other bridges in the Kaohsiung area of the Second Freeway Extension Project. In Taipei, a detailed description of the Hsichih-Wuku widening project was provided.



Figure 11. Youngjong Bridge (Artist rendering courtesy of KHC).

The Taiwan Area National Freeway Bureau is responsible for road maintenance, traffic management, toll collection, motorist services, and freeway widening. The Taiwan Area National Expressway Engineering Bureau has responsibility for planning, designing, and constructing the national expressway network in Taiwan. The Bureau is organized into the headquarters office and district project offices. The headquarters office is responsible for project planning, design, land acquisition, bidding, and construction. The district project offices are responsible for the management of construction operations.

The Second Freeway Extension Project involves the construction of a 320-km (199-mi)-long main route plus four branch routes with a total length of 68 km (42 mi). The project includes the construction of 610 bridges and five

tunnels. Visits by the team were made to the Kao-Ping River Bridge on the main route and numerous bridges on the Kaohsiung Beltway and the Chishan Branch.

The main structure on the Kao-Ping River Bridge, depicted in Figure 12, will be a single pylon cable-stayed bridge with span lengths of 330 and 180 m (1,083 and 591 ft). The inverted Y-shaped concrete pylon will have a total height of 180 m (591 ft). Foundations for the pylon were constructed using a slurry wall. The superstructure for the main span will be constructed with structural steel. The side span will be built with prestressed concrete. The structural steel segments will be assembled using all-welded construction on site at an area adjacent to the pylon. The segments will be erected by lifting from the superstructure. The concrete segments will be cast-in-place on a falsework sys-



Figure 12. Kao-Ping River Bridge (Artist rendering courtesy of MOTC).

tem and will be constructed before the main span segments are erected. At the time of the visit, about two-thirds of the inclined legs of the pylon had been constructed, as shown in Figure 13.

The stay cables will consist of a 15.2-mm (0.6-in.)-diameter seven-wire strand system produced by Vorspann Technik of Austria. In this system, the individual strands are coated with grease inside a polypropylene tube. The whole cable is enclosed inside a polypropylene tube that is filled with wax. Wedge anchors are used at the ends of the strands. When completed, the Kao-Ping River Bridge will be the longest span bridge in Taiwan.

Other bridges on the second freeway extension project are being constructed using the following systems:

- Constant depth, precast concrete segmental box girders erected by the balanced cantilever method with an erection truss or cranes.
- Constant depth, cast-in-place concrete box girders constructed span by span using an advancing shoring system.
- Constant depth, concrete box girders using the incremental launching method. Launching is accomplished by pulling the rear end of the bridge towards the abutment using strands.
- Variable depth, cast-in-place concrete segmental box girders erected by the balanced cantilever method and travelling formwork.
- Post-tensioned I-shaped concrete girders.
- A combination of precast concrete slabs and cast-in-place construction as illustrated in Figure 14.

For the balanced cantilever method with travelling formwork, the cantilevers were constructed with a one-half length of segment out of balance to reduce the overturning moment. End spans were also being constructed using form travellers and falsework towers.



Figure 13. Kao-Ping River Bridge under construction.



(a)

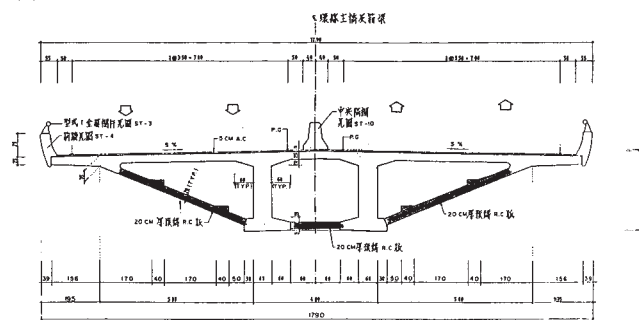

(b)

橋梁斷面圖

Figure 14. Combination of precast slabs and cast-in-place construction (Diagrams by MOTC). (a) Underside of structure; (b) Cross section

The Sun-Yat-Sen Freeway is a 373-km (232-mi) stretch of highway in northern Taiwan opened in 1978. Since that time, traffic on the freeway has grown at an annual rate of 10 percent. Additional lanes have been added using the center median and the shoulders to increase the capacity. However, further widening at grade level became impractical. Consequently, it was decided to widen the freeway by adding elevated structures on each side of the existing freeway over a length of 21 km (13 mi). This project is known as the Hsichih-Wuku widening project. For 13.5 km (8.4 mi), two lanes were added on each side and for 7.5 km (4.7 mi) three lanes were added. The widening provided a means to separate long distance traffic from local traffic with long-distance traffic using the new construction, as shown in Figure 15. The overall cost of the project including land acquisition and compensation was reported to be NT\$31.2 billion (\$1.1 billion U.S. in September 1997).

Several different construction methods were used for the foundations of the 954 piers. These included reverse circulation drilled piles, full casing drilled piles, caisson foundations, precast piles, and shallow footings. The 40.4-km (25.1-mi) length of elevated structure used many differ-



Figure 15. Hsichih-Wuku widening project.

ent structural types. Approximately one-third of the superstructure was built using prestressed concrete I-girders and about one-quarter used steel box girders. Other types included cast-in-place, segmental box girders built by the balanced cantilever method; cast-in-place, double-tee girders; precast concrete box girders; precast, prestressed single-tee girders; and hollow slabs.

In Taipei, the team visited the Freeway Traffic Surveillance and Control Center of the Taiwan Area National Freeway Bureau. The control center uses an “on-line real time” integrated system and uses automated monitoring of traffic conditions with roadside equipment, centralized processing and control systems, and information transmission and communications equipment.

## SUMMARY OF RECOMMENDED TECHNOLOGIES

On the basis of the observations made during the scanning review, the team developed a list of 30 topics for possible application by public and private agencies in the United States. The list was then divided into 6 high-priority, 7 medium-priority topics, and 17 other topics for consideration at a later date. A summary of the topics and recommendations for implementation are given in this section. More details of the technologies are given later.

### High-Priority Topics

#### *Dimple Pipe for Exterior of Stay Cables*

Vibrations of stay cables can be a serious problem under certain weather conditions. On the Tatara Bridge in Japan, a black polyethylene pipe with a dimpled outer surface is used to reduce vibrations caused by wind and rain.

**Recommendation:** *The FHWA should make information about the pipe available to the U.S. bridge engineering community.*

### *Nonsegregating Flowable Concretes*

For the cable anchorages of the Akashi-Kaikyo Bridge, HSBA used a self-healing highly flowable nonsegregating concrete. The concrete mix included a low-heat cement, limestone powder, superplasticizer, and 40-mm (1.6-in.) maximum size coarse aggregate. The concrete was specified to have a flow of 500 mm (120 in.), air content of 4 percent, and a 91-day compressive strength of 30 MPa (4,350 psi).

**Recommendation:** *The FHWA, in cooperation with State DOTs, should sponsor high-performance concrete demonstration projects to show the advantages of using flowable concretes in areas of congested reinforcement. Information on this product should be made available to the American Concrete Institute, National Ready Mixed Concrete Association, and the Portland Cement Association.*

### *Computerized Assembly and Testing System (CATS) for Steel Components*

The Yokogawa Bridge Corporation has developed a new computerized system to simulate erection of complicated structures and to eliminate the need for shop assembly of bridges. CATS uses photogrammetry methods with four cameras to take 3-D pictures of each element. The shape and dimensions of the members are obtained by linking the data from the cameras and other measuring devices. The members are then “shop assembled” in simulation on the computer screen using software developed for that purpose. Any corrections that need to be made to the members are identified. Actual measurements are compared with the design data to identify production errors. This innovation removes the need for shop assembly, while ensuring accuracy. In addition, information, such as camber and joint widths, for assembling the bridge at the construction site is developed.

**Recommendation:** *CATS should be studied further by the American Institute of Steel Construction, the American Iron and Steel Institute, and the National Steel Bridge Alliance, and research considered to develop a system that can be used in the United States. Copies of this scanning review report, including the translation of the CATS brochure, should be made available to trade associations for distribution to their members.*

### *Nonmetallic Removable Back-Up Bars for One-Sided Welding*

HSBA makes use of steel bridge decks for all its major bridge projects. These are orthotropic bridge decks field welded from one side only. HSBA uses a temporary, nonmetallic back-up bar attached to the bottom of the deck plate using adhesive strips on the bar. The bar has a concave surface on the side attached to the deck to allow some over-



reinforcement on the bottom side of the weld. The bar can be easily removed for inspection of the weld after completion. The back-up bar used in Japan appeared to differ from the ceramic bars available in the United States, and it was implied that the cost of the Japanese bars was much lower. Potentially, the use of a similar back-up bar with adhesive strips in the United States can provide cost-effective quality improvements in U.S. welding processes.

**Recommendation:** *A research funding agency (e.g., the FHWA, NCHRP, or other organization), in cooperation with the American Institute of Steel Construction, American Welding Society, and the National Steel Bridge Alliance, should perform research to investigate one-sided welding using the nonmetallic back-up bars that are being used in Japan. Possible applications in the United States should be determined.*

#### *Dry Air Injection System for Corrosion Protection of Cables*

The latest HSBA system for corrosion protection of the main cables of suspension bridges consists of the injection of dry air into the main cable interior. The goal is to keep the humidity level inside the cable below 40 percent. In addition to the use of this system on new suspension bridges that will not have any anti-corrosion paste installed, HSBA plans to retrofit suspension bridges that were constructed with an internal anti-corrosion paste. These built structures are quite similar to suspension bridges in service in the United States today.

**Recommendation:** *A research-funding agency (e.g., the FHWA, NCHRP, or other organization) should perform a more detailed investigation of the dry air injection system to determine how it can be used on existing and future bridges in the United States. Although HSBA is using the concept for suspension bridges, its possible use in other applications such as cable-stayed bridges should be evaluated.*

#### *Special Paint Primer*

In cooperation with major steel producers, PWRI has been testing and evaluating a significant improvement in corrosion protection technology. This technology is a new spray-on product that was referred to as “suspicious primer.” The spray-on primer product stimulates the formation of the chromium steels. This product was successfully tested by PWRI and sent to all major steel suppliers in Japan to have additional independent testing conducted. Over the last year, test results have been positive. The product would be used on all bridge steels, regardless of grade and chemical make-up. The

product is commercially available from Sumitomo Metal Industries, Ltd., as the “Weather-Act Method.” Successful usage of this product has the potential to enhance protection practices of steel bridges in the United States.

**Recommendation:** *The FHWA should obtain detailed information about this product from Sumitomo Metal Industries. If warranted, trial samples should be obtained and tested in the United States. Information should be made available to state DOTs.*

#### **Medium-Priority Topics**

##### *Balanced Cantilever Construction with Alternate Segments Offset by 1/2-Segment Length*

The technique of constructing balanced cantilever cast-in-place concrete bridges with alternate segments offset by a 1/2-segment length is used in Taiwan to reduce the out-of-balance moment at the pier.

**Recommendation:** *The FHWA should provide this scanning review report to the American Segmental Bridge Institute (ASBI) for distribution to its members. Owners, designers, and contractors should consider using this technique in construction.*

##### *Full Cantilever Erection for End Spans of Balanced Cantilever Bridges*

In Taiwan, it was noted that end spans were constructed using form travelers and the cantilever method. A temporary pier was provided near midspan to allow the cantilevering to continue to the abutment. Hydraulic jacks were installed between the temporary pier and the box girders to adjust for any settlements. This technique eliminated the need for continuous shoring that is frequently used in the United States.

**Recommendation:** *The FHWA should provide this scanning review report to ASBI for distribution to its members. Owners, designers, and contractors should consider using this concept for end span construction of bridges erected by the cantilever method.*

##### *Nonseparating (Desegregating) Tremie Concretes*

For the underwater concrete tower foundations of the Akashi-Kaikyo Bridge, a special nonseparating concrete was used. The concrete contained a high-range water-reducing admixture to achieve flowability and an anti-washout ad-

mixture to obtain viscosity. An anti-washout admixture is available from at least one supplier in the United States, but is not used extensively.

**Recommendation:** *The FHWA, in cooperation with state DOTs, should sponsor high-performance concrete demonstration projects to show the advantages of using non-separating concretes for underwater construction. Information on this product should be made available to the American Concrete Institute, the National Ready Mixed Concrete Association, and the Portland Cement Association.*

#### *19-Wire Prestressing Strands*

The Japanese have developed 19-wire prestressing strand with diameters of 17.8, 19.3, 20.3, and 21.8 mm (0.70, 0.76, 0.80, and 0.86 in.). The strands consist of two concentric layers of wire wrapped around a center wire. Each concentric layer consists of nine wires. The strand has a specified minimum strength slightly less than Grade 270 strand. The largest strand has a minimum breaking strength of 3.1 times the strength of a 12.7-mm (0.5-in)-diameter Grade 270 strand. The 19-wire strand developed in Japan has potential application for transverse post-tensioning of bridge decks and prestressing high-strength concrete beams.

**Recommendation:** *A research-funding agency (e.g., the FHWA, NCHRP, or other agency) should develop or undertake a research project to develop design information for use with 19-wire strand. Design recommendations for the AASHTO Specifications should be developed.*

#### *Wrapping Wire with Interlocking Cross Section*

On the Kurushima Bridges, a wrapping wire with an S-shaped cross section, developed by Nippon Steel Corporation, will be used to wrap the main cables. The cross section of the wire is designed so that the two legs of the S interlock. The interlocking provides a tighter seal against moisture penetration compared to wrapping with conventional wire having a circular cross section.

**Recommendation:** *The FHWA, in cooperation with an owner, should pursue the use of interlocking wire on the next suspension bridge to be built in the United States.*

#### *Flame or Thermal Spray Metallizing*

PWRI has been working with an improved thermal spray system. The new thermal spray system uses lighter equipment and considerably less heat. The primary innova-

tion is the metal used for the thermal spray, which is a 50:50 combination by volume of zinc and aluminum. It is expected that this system offers the best alternative for thermal spray applications. At the present time, its use has been reserved for long-span bridges because of the high cost.

**Recommendation:** *The FHWA should incorporate tests of the improved thermal spray system and the 50:50 zinc-aluminum spray into existing research projects for methods of controlling corrosion.*

#### *Translation of Relevant Sections of the HSBA Specifications into English*

HSBA has developed its own specifications for long-span bridges.

**Recommendation:** *The FHWA should have relevant sections of the HSBA specifications translated into English and distribute the translations to appropriate organizations.*

#### **Other Topics**

##### *Research on Punching Shear Failure*

In all three countries, the topic of punching shear failures of bridge decks associated with cracking and fatigue was mentioned. Each country had a slightly different explanation for the mechanism.

**Recommendation:** *A research-funding agency (e.g., the FHWA, NCHRP, or other organization) should support a research project to determine if punching shear failure caused by fatigue of concrete is a failure mode that needs to be considered in the design of bridges in the United States. If required, appropriate design recommendations for the AASHTO Specifications should be developed.*

##### *Bolted Connections for Earthquake Resistance*

The Japanese are evaluating the use of bolted connections to improve seismic resistance of steel structures.

**Recommendation:** *The American Institute of Steel Construction, American Iron and Steel Institute, FHWA, or National Science Foundation should evaluate this concept and consider initiation of a project to determine if the use of bolted connections in bridge structures or buildings will improve their seismic resistance. If appropriate, design procedures should be developed.*

### *Mechanical Damping Devices to Control Vibrations of Steel Towers*

HSBA has incorporated tuned mass dampers into its bridge towers to control vibrations both during construction and during the service life of the bridge. In the United States, this technology has been limited to buildings.

**Recommendation:** *Owners and designers of tall bridge structures are encouraged to consider this approach for new structures and as a retrofit for existing structures,*

### *Forced Vibration Tests on Completed Bridges*

The response of large bridges to wind and earthquake loads is an important aspect of design. Design assumptions about actual dynamic characteristics, such as natural frequencies and damping characteristics, can be determined by forced vibration tests on completed bridges. Information can be used to improve design procedures.

**Recommendation:** *A national research effort should be initiated to evaluate the benefit of full-scale dynamic testing of bridges in the United States.*

### *Special Railway Expansion Joints for Flexible Long-Span Bridges*

On the Kojima-Sakaide Route, which carries a railroad on the lower deck, special joints were needed to accommodate rotation and longitudinal movements.

**Recommendation:** *The FHWA or NCHRP should distribute copies of this scanning review report to the AAR, the American Railway Engineering and Maintenance Association, and the FRA informing them about the railway expansion joints used by HSBA.*

### *Pneumatic Caissons with Remote Control Equipment for Underwater Construction*

Construction of each tower foundation for the Youngjong Bridge uses pneumatic caissons, six remote-controlled excavators, and closed-circuit television. Instrumentation is provided to measure water levels, current speed, caisson elevations, and tilt. Construction is monitored and controlled from a separate control room.

**Recommendation:** *The FHWA should provide this scanning review report and other information about the use of remote-controlled equipment for underwater construction to the state DOTs and contractor's trade associations for distribution to their members.*

### *Slurry-Wall Construction for Tower Foundations*

On the Kao-Ping River Bridge, the foundation for the main pier was being constructed using slurry walls to carry the pier loads.

**Recommendation:** *The technique of using slurry walls to transfer pier loads to bedrock should be considered by designers as an alternative foundation system to reduce the amount of excavation required.*

### *High-Strength Silicon Steel Wire*

In Japan, a high-strength silicon steel wire with tensile strength of 180 kgf/mm<sup>2</sup> (256 ksi) has been developed for use in suspension cables in long-span bridges. The cable was first used in the Akashi-Kaikyo Bridge. HSBA reported that the bridge design would have required four main cables with traditional strength wire. The high-strength silicon wire, in combination with a lower factor of safety for the cable, allowed the use of only two cables, thereby significantly reducing the weight and cost of the structure.

**Recommendation:** *The FHWA, in cooperation with wire producers, should conduct research to demonstrate the properties of high-strength silicon wire for use in suspension cables and to evaluate its potential use in other applications.*

### *Steels Containing a Higher Percentage of Nickel*

The Japanese have a weathering steel that is essentially equivalent to U.S. steel grades A709-50W and 70W, respectively, with the exception that the nickel content is increased from about 0.3 percent to about 3 percent. Similar steels are available in the United States under the ASTM A710 specification, but steels meeting this specification are not currently allowed by AASHTO for use in bridges.

**Recommendation:** *A research-funding agency (e.g., the FHWA, NCHRP, or other organization), should initiate research to evaluate corrosion-resistant steels currently available under the ASTM A710 specification to determine their suitability for use in bridge structures. If it is determined that the properties are adequate, the AASHTO Materials Specifications should be modified to allow their use. This will give engineers another tool for use in difficult environments.*

### *Vibration Damping Steel Plates*

The Japanese have produced a composite vibration damping steel plate that consists of a 0.15- to 0.3-mm (0.006- to 0.012-in.) layer of visco-elastic resin sandwiched

between two 2.3- to 10-mm (0.09- to 0.39-in.)-thick steel plates. In this plate, the shear deformation of the visco-elastic resin layer caused by the vibration has the effect of damping the vibration. The product was developed for use in structural members to reduce the noise emitted from elevated highways and rail lines in dense urban areas.

**Recommendation:** *A research-funding agency (e.g., the FHWA, NCHRP, or other organization) should undertake a study to evaluate potential applications for the vibration damping steel plates and, if appropriate, conduct a demonstration project.*

#### *Thermo-Mechanical Control Processing or Similar Technology*

In the Nippon Steel Corporation Plant, thermo-mechanical control processing (TMCP) equipment was being used in the rolling mill. TMCP consists of applying accelerated cooling or direct quenching of the plates during the rolling process, resulting in plates with higher strength and toughness without increased alloy content. TMCP also allows the production of plates with lower carbon equivalent numbers, a property that greatly improves weldability. The result is that plates with yield strengths greater than 345 MPa (50 ksi) can be produced on line. On-line processing does not limit the length of plate that can be produced. Conventional off-line quenching and tempering can be used to obtain similar steel properties, but the process is more expensive to perform and only a few U.S. fabrication shops apply this technology to bridge construction. Current off-line quenching and tempering in the United States limits plate lengths to about 15 m (50 ft). This can increase the number of welded splices required to fabricate a bridge girder, thereby increasing cost.

**Recommendation:** *The U.S. steel industry should be encouraged to introduce TMCP or similar technology into its plants as a means of reducing the cost and improving the quality of high-performance steels.*

#### *Truss Elements that Taper to I-Sections at the End Connections*

HSBA utilizes innovative truss elements in its stiffening girders. These elements are fabricated as four-sided boxes or tubes. However, toward the ends of the sections, two of the four sides are transitioned into a single web section and the other two sides continue through to create a wide flange I-section that can be connected on two sides. The two sides greatly simplify the bolted connections at team points where multiple members come together.

**Recommendation:** *The FHWA or NSBA should initiate a*

*project to demonstrate how the use of truss elements that taper to two-sided I-section members at the end connections can greatly simplify and facilitate member connections in new and rehabilitated bridges.*

#### *HSBA Paint System*

For protection of its steel structures from corrosive sea environments, HSBA has developed long-life coating systems comprising either polyurethane or fluoro-polymer paints. The paint system is specified in the HSBA Painting Standard for Steel Bridges. This document, written in Japanese, was supplied to the team.

**Recommendation:** *The HSBA Specification on Paint Systems should be translated into English and the information evaluated. If warranted, trial samples of the paint should be obtained and tested in the United States. Information should be sent to all state DOTs with recommendations for use.*

#### *Asphalt Overlays for Orthotropic Steel Decks*

The Japanese have many bridges with orthotropic steel decks protected by an asphalt system.

**Recommendation:** *The FHWA or NCHRP should obtain more information about the specifications, performance, and cost-effectiveness of using only asphalt overlays to protect orthotropic steel decks. Recommendations should be made for use of this technique in the United States.*

#### *Built-In Access and Utilities for Bridge Inspection and Maintenance*

On the HSBA bridges, built-in travellers, lifts, gantries, and catwalks are provided to facilitate close-up inspection and maintenance.

**Recommendation:** *Bridge owners should put greater emphasis on requiring that this equipment be installed on major bridges in the United States during initial construction. This will make frequent inspection of bridges more feasible and will simplify access for maintenance.*

#### *Repair Robot for Use in Inaccessible Areas*

HSBA, in cooperation with the Japan Construction Methods and Machinery Research Institute, has developed a repair robot to travel over bolted steel surfaces of structures. The robot is equipped with a work-head assembly, magnetic wheels, and TV cameras.



**Recommendation:** *The FHWA should evaluate potential applications of the HSBA robot on U.S. bridges and determine if its use should be pursued.*

#### *Public Relations Programs for Major Projects*

Many of the construction sites had excellent visitors' centers and excellent informational materials for distribution.

**Recommendation:** *Bridge owners and the FHWA should develop informational packages for all major bridge and roadway projects to promote public and professional awareness of the benefits of bridge and highway investments.*

## **DESIGN STANDARDS, CODES, AND SPECIFICATIONS**

Design standards, codes, and specifications in the three countries use an approach similar to that used in the United States. Design live loads are being driven upward by the need to design for heavier and multiple trucks. In Japan, special emphasis is now being given to seismic design. Specific items for each country are given in the following sections.

### **Japan**

Design specifications for highway bridges in Japan are prepared by the Japan Road Association, which is equivalent to AASHTO. The specifications are developed by committees in a similar manner to the AASHTO specifications. *The Highway Bridge Specifications* consist of five parts:

1. General
2. Steel Bridges
3. Concrete Bridges
4. Substructures
5. Seismic Design

In general, bridge design in both concrete and steel is based on the allowable stress approach. However, seismic design is based on ultimate strength. The design specifications reference Japanese Industrial Standards (JIS) for quality control and mechanical properties of materials. The JIS used to be revised on a 10-year cycle. However, recent events have resulted in more frequent changes. When materials not covered by JIS are used, technical experts are consulted and a committee review process is adopted. *The Highway Bridge Specifications* apply to span lengths up to 200 m (656 ft) and are revised every 4 to 5 years. The seismic design specification was extensively revised after the Great Hanshin Earthquake in 1995.

A guideline for limit state design of concrete structures has been developed by the Japan Society of Civil Engineers (JSCE). Introduction of limit state design into practice has been limited because there are no specific criteria to determine the appropriate load and resistance factors. For fracture critical steel members, no damage is allowed under service loads. Partial damage is allowed under unlikely events such as unexpected live loads and big earthquakes, but catastrophic failure is not allowed. Redundancy with fracture critical members has not been well recognized and there are no provisions for redundancy. For seismic design, there are two levels. At Level I, the structure is designed to survive with no damage. At Level II, some damage is allowed. The Japanese have seen evidence of fracture of steel members from low cycle fatigue occurring as a result of seismic loading. Strains were in the range of 10 to 20 percent.

Since HSBA deals with combined road and railway bridges and with span lengths longer than 200 m (656 ft), they have developed their own design standards for superstructure design, wind-resistant design, seismic design, and substructure design. These standards allow the use of higher tensile strength steels. HSBA standards use the allowable stress design approach with some movement toward a limit states method which HSBA sees as an international approach. The use of a lower factor of safety for the main cables of the Akashi-Kaikyo Bridge because of the high dead load reflects a limit states approach. A copy of the HSBA specifications in Japanese was given to the team.

### **South Korea**

Codes and specifications in South Korea are revised mainly by the Ministry of Construction and Transportation on a cycle of about 6 years. The revisions are made by a committee that performs research work and reports to a specialist consultant team that develops the final revisions. The Ministry informs the relevant authorities for implementation.

The design approach in South Korea is very similar to that in the *AASHTO Standard Specifications for Highway Bridges*. However, 33 percent larger truck loads are used due to the increasing number of larger sized vehicles in the country. Other design loads include ship impact and temperature gradients. Steel structures are designed using the permissible stress design method. Prestressed concrete structures are designed for service loads and then checked for factored loads. The Koreans anticipate that the load and resistance factor design method will be used in the future.

For seismic design, the country is divided into two zones for selection of acceleration factors. Single-mode analysis methods are generally used, but for structures requiring more complex analysis, multi-mode methods are used. The seismic design standards are in the process of being rewritten.



## Taiwan

In Taiwan, bridge design is based on the Highway Bridge Specifications published by the Ministry of Transportation and Communications. Reference is also made to the *AASHTO Standard Specifications for Highway Bridges* and the *CALTRANS Bridge Design Specifications Manual*. The current specifications were developed in 1989. They are being updated and should be complete by 1999. It also appeared that the basic specifications are modified for specific projects.

A live load equivalent to HS20-44 + 25% is used. The service load design method is used for foundation design. The load factor design method is used for columns. Service load design or load factor design is used for the superstructure.

## Recommendations on Design Standards, Codes, and Specifications

The *AASHTO LRFD Bridge Design Specifications* may represent a model document that could be used in these countries as they move toward an LRFD design approach. The United States should stay current on the Japanese provisions for wind loads, water loads, scour, seismic design, and new materials. The team recommends that FHWA arrange for the translation into English of the relevant sections of the HSBA specifications.

## DESIGN AND CONSTRUCTION PRACTICES

### Japan

In Japan, it is a requirement that bridges and viaducts be constructed economically and effectively in a short period of time to meet the rapid increase in traffic. The team learned that JH and PWRI have been directed to lower costs by 10 percent and to introduce life-cycle costing. The team also observed that both gasoline taxes and tolls are relatively much higher than in the United States.

A breakdown of the various types of structures and their applicable span lengths as published by JH is given in Table 3. Steel structures are used for longer span lengths, whereas in the United States concrete is more competitive for longer span lengths.

Many of the superstructures of existing Japanese bridges are built of steel to reduce weight and the resulting seismic forces. These structures are typically plate girder bridges because of economy and ease of fabrication. Design is generally based on noncomposite action between the concrete deck and steel girders because of ease of maintenance. Box girders are used where girder depth is limited and on small radius curves. Elevated viaducts are used extensively in urban areas because of the shortage of land. Steel substructures

are used to minimize the size of the footprint. Great emphasis is placed on doing as much work as possible in the prefabrication plant and minimizing labor at the expense of material weight. For longer spans, truss bridges, cable-stayed bridges, and suspension bridges are used. A unique feature noticed on the HSBA routes was the use of continuous suspension bridges such as the Kurushima Bridges and Bisan-Seto Bridges and the use of continuous cable-stayed bridges such as the Hitsuishijima and Iwakurojima Bridges.

Concrete bridges consist of reinforced concrete box girders, prestressed concrete composite girders, and prestressed concrete box girders erected using the cantilever method. Current emphasis is directed to methods of mechanizing the construction process to reduce labor requirements. Reinforced concrete box beams are used on expressways for bridges with span lengths of 15 to 17 m (49 to 56 ft). Prestressed concrete girders are the standard for bridges with span lengths of about 30 m (100 ft). For long span lengths, box girders constructed by the balanced cantilever method are used. The use of precast concrete segments is leading to shorter construction times.

For short span bridges, standard plans and details are used and the process is largely automated. Although it was difficult to obtain precise numbers, there is a trend toward the greater utilization of concrete superstructures as steel is becoming less competitive than precast concrete for span lengths of 60 to 100 m (200 to 330 ft).

During the design phase of special structures, several alternate types of bridges and construction methods are considered but only one final design is prepared for bidding. HSBA makes a complete independent check on the analysis of all its major bridges. After award of the contract, only small changes may be proposed by the contractor. There is no incentive for contractors to submit alternative designs as major changes are only made by the owner and, in this situation, the job price is recalculated and the contractor returns all savings. The Japanese have limited experience with value engineering and design-build contracts. In some situations, JH does the basic design and allows the contractor to do the detailed design. The usual bidding process also involves separate contracts for the substructure and the superstructure, whereas for most bridges in the United States, only one contract is used. The use of two contracts was evident on several multi-span bridges where the substructures for many spans were complete but the superstructure erection was a long way behind.

### *Extradosed Concrete Bridges*

JH has built and is considering many innovative structures. Among the innovative types that it has developed is one described as the "Extradosed Concrete Bridge." A photograph of this type of bridge is shown in Figure 16. This bridge is similar in appearance to a small cable-stayed bridge but with a low tower height. However, the bridge is more

TABLE 3 Span lengths of bridges in Japan

Type and Structure	Span, m			
	10	50	100	140
<b>Steel Bridges</b>				
Simple composite girder		—		
Simple girder		—		
Continuous girder		—		
Simple box girder		—		
Continuous box girder		—	—	
Simple truss		—	—	
Continuous truss		—	—	—
Inverse Ranger girder		—	—	—
Inverse Rohse girder		—	—	—
Steel plate arch			—	—
<b>Prestressed Concrete Bridges</b>				
Pretension girder	—			
Hollow slab	—	—		
Simple T-shaped girder	—	—		
Simple composite girder	—	—	—	
Connected composite girder	—	—		
Continuous composite girder	—	—		
Simple box girder	—	—		
Continuous box girder (cantilever erection)		—	—	—
Continuous box girder (with scaffolding)		—	—	
“π-Type” rigid frame with diagonal		—	—	
<b>Reinforced Concrete Bridges</b>				
Hollow slab	—			

appropriately considered as a modification of a conventional precast concrete cantilever bridge type. The innovation takes the prestressing tendons outside the box's cross-section and attaches them to a single tower. The prestressing cables are attached to the superstructure's elements using cable-stayed bridge practice. The bridge resembles the Ganter Bridge in Switzerland except the cables are exposed in the Japanese version. This is a further evolution beyond current U.S. practice that utilizes external and internal tendons all located inside the cross section. Advantages of this concept include the ease and standardization of casting operations, reduced tower height, less stress range in the cables, and no necessity to adjust cable forces. Several bridges of this type are being designed in Japan. U.S. standardization efforts now being conducted by the American Segmental

Bridge Institute, the Precast/Prestressed Concrete Institute, and AASHTO should be made aware of this innovation for their consideration.

#### *Collision Protection Systems for Ships and Piers*

HSBA uses vessel collision systems designed to protect ships as well as bridge piers. In the United States, the primary goal in the design of dolphins, fenders, and piers is to provide protection of bridge piers. Minimizing ship damage has not been a priority in design philosophy. Among the choices HSBA considers are cellular steel buffer systems and 1-m (3-ft)-long breakaway plastic rods adhered to the facing teams of their piers to absorb the collision impact of a

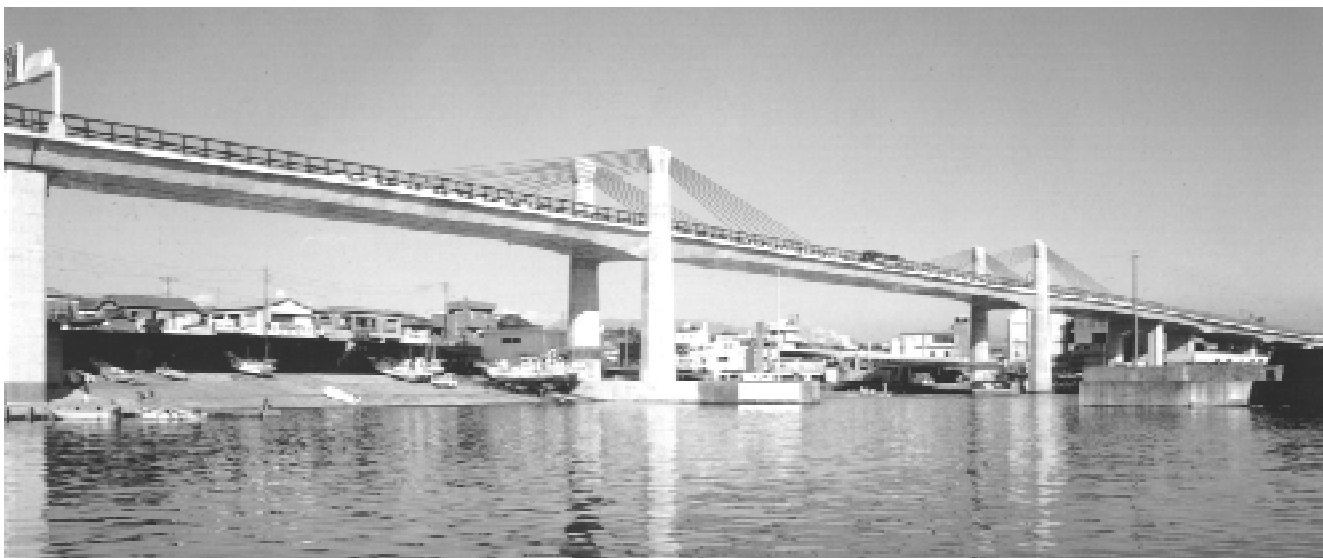

Figure 16. *Extradosed concrete bridge (Photo by JH).*

vessel. This minimizes ship damage and protects the pier. The pier protection system used on the Akashi-Kaikyo Bridge is shown in Figure 17. The concept is a major innovation. Any number of configurations can be made once the concept is considered in design.

#### *Concrete Deck Fatigue*

The Japanese think that repeated loads are a primary factor that is contributing to premature failure of their concrete bridge decks. It was reported that bridges are subjected to illegal overloads that are much greater than design loads. PWRI explained that the failure mechanism starts with the formation of transverse cracks from shrinkage and overloads. These cracks grow larger under repeated live loads. Longitudinal cracks then begin to appear possibly caused by overloads. At some point, the cracks start to propagate more in a shear mode than a bending mode. This divides the deck into a series of rectangular blocks. Water penetrates the cracks and leaches out the cement which further reduces the shear capacity. Finally, a punching shear type of failure occurs resulting in holes in the deck. For bridges designed before 1980, punching shear of decks was not considered in design. It is unknown how much of an effect corrosion of reinforcing steel plays in accelerating this process. The Japanese are not sure of the exact failure mode for this phenomenon. Consequently, bridges are designed to be non-composite.

PWRI is actively researching the fatigue performance of full-scale concrete deck teams using new hydraulic equipment capable of applying a moving wheel load in the laboratory. Currently, no research results have been published.

PWRI is also using weigh-in-motion systems to determine actual truck loads.

This type of punching failure has been observed in the United States. However, chloride penetration and corrosion of steel reinforcement have been identified as the primary causes. In the United States, epoxy-coated steel reinforcement or other corrosion protection systems are expected to reduce this type of problem for most modern bridge decks. If the mechanism of deterioration is more fatigue related than corrosion related, it is possible that deck failures will occur, even with the corrosion protection systems. Unfortunately, it will take many years before this is known. Under NCHRP Project 12-37, factors contributing to transverse cracking of newly constructed bridge decks were identified. However, the project did not address the effect of transverse cracks or the structural integrity of bridge decks or the causes and effects of longitudinal cracks. Consequently, this problem should be studied further in the United States.

#### *Bolted Connections for Earthquake Resistance*

During the visit to the Steel Structures Development Center of the Research and Engineering Center at Nippon Steel Corporation, tests were being performed on full-size bolted beam-column connections for rectangular column members. The tests were being conducted using short duration real-time dynamic displacements to represent earthquakes. The objectives of the research were to develop retrofitting methods and to develop design codes for large earthquake loadings. During the Great Hanshin Earthquake, weaknesses occurred in some welded corner connections. This has been duplicated in the laboratory. Subsequent tests

(a)

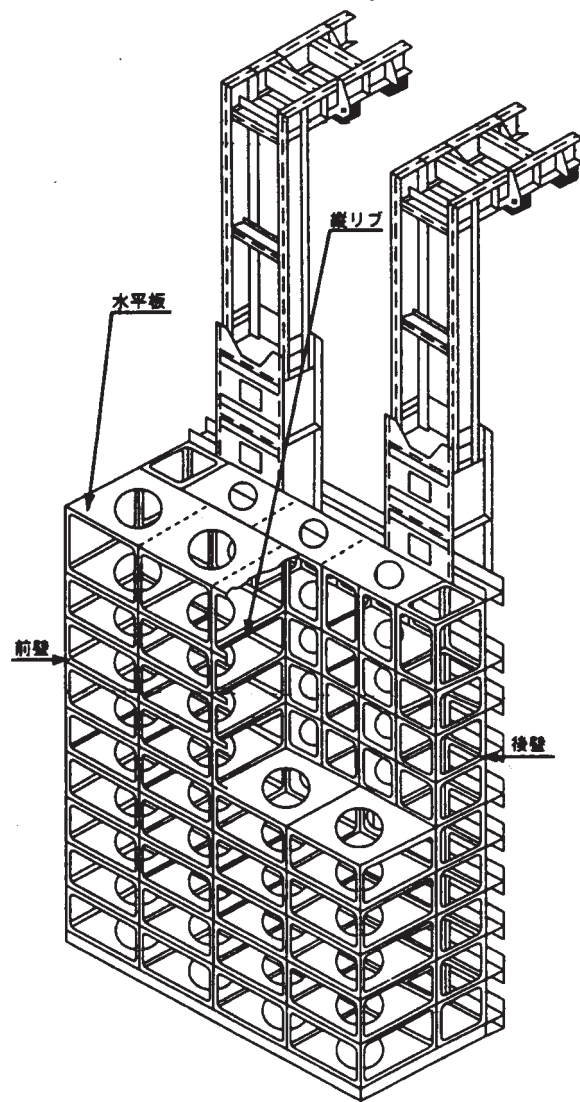

(b)

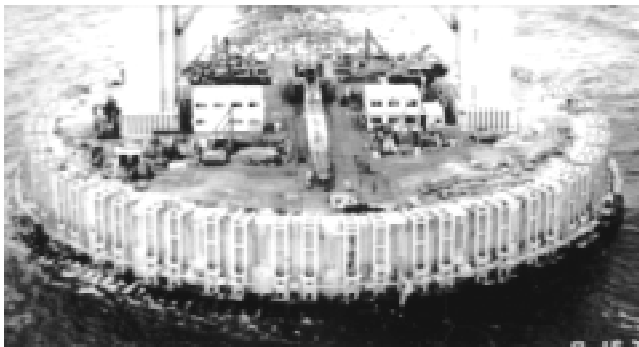

Figure 17. Pier protection on Akashi-Kaikyo Bridge. (a) Schematic (Diagram by HSBA); (b) Base of pier.

have been used to examine an alternative configuration using bolted connections, angle reinforcement, and corner diagonal plates.

#### Quality Control

For quality control during construction, the contractor is required to submit a working plan to the agency. The contractor has primary responsibility for quality control. The team was informed that HSBA and JH do not perform construction inspection. The system is based on credibility between the agency and the contractor. The contractor checks that materials conform to JIS and the manufacturer provides a warranty. For materials not covered by JIS, a special warranty is required. By comparison, most agencies in the United States provide their own inspectors for bridge construction.

The team was impressed with the precision used by the Japanese in construction. A high degree of precision is necessary because of the extensive use of off-site prefabrication which does not allow for large variances on the site. On the Akashi-Kaikyo Bridge, the tops of the towers were within 20 mm (3/4 in.) of their planned location. At Kurushima, the caissons were precisely positioned, the verticality of the towers was carefully checked and the superstructure was erected from a self-positioning barge. This self-positioning system used triangulation with two fixed light wave sources on land to automatically control the position of the barge in the strong currents of the straits. This application is an example of the use of a global positioning system in construction.

#### On-Site Monitoring

HSBA also does extensive on-site monitoring to determine the actual dynamic characteristics of the bridges for comparison with design assumptions. For example, structures are monitored for accelerations from both wind and earthquakes. During construction of the Akashi-Kaikyo Bridge, the towers were excited with vibrators to verify that the tuned mass dampers performed as planned. The superstructure on one of the Kojima-Sakaide Route bridges was also subjected to forced vibration testing. By contrast, very little testing of completed bridges is performed in the United States.

#### Expansion Joints

On the long structures built by HSBA, special expansion joints are needed to accommodate the longitudinal movements. This link-type joint is patented by HSBA and Sumitomo Metal Company. The riding surface of the expansion joint on the Akashi-Kaikyo Bridge is shown in Fig-



Figure 18. Riding surface of the expansion joint on the Akashi-Kaikyo Bridge.

ure 18. The scissor-type arrangement that supports the steel fingers is shown in Figure 19.

On the Kojima-Sakaide Route, which carries a railroad on the lower deck, special joints were needed to accommodate rotation as well as expansion and contraction. Figure 20 shows two schematic diagrams of a joint that spreads the change in slope over several locations separated by about 15 m (50 ft). In addition to accommodating rotation, these

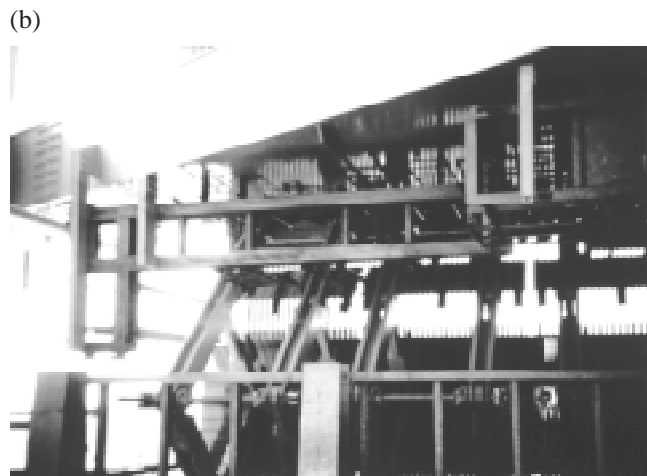
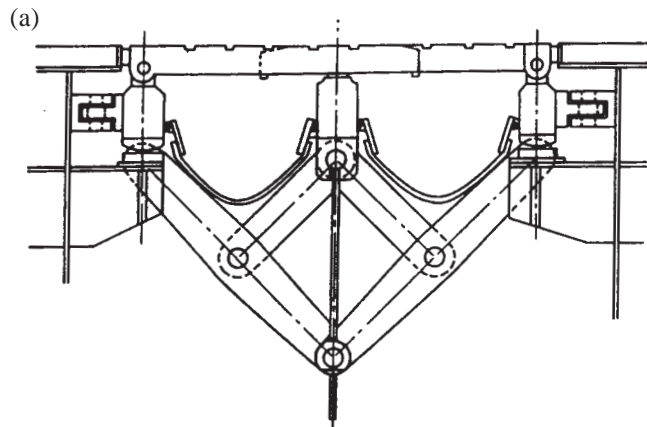

Figure 19. Scissors expansion joint (a) HSBA scissors expansion joint (Diagram by HSBA); (b) Underside of expansion joint on Akashi-Kaikyo Bridge.

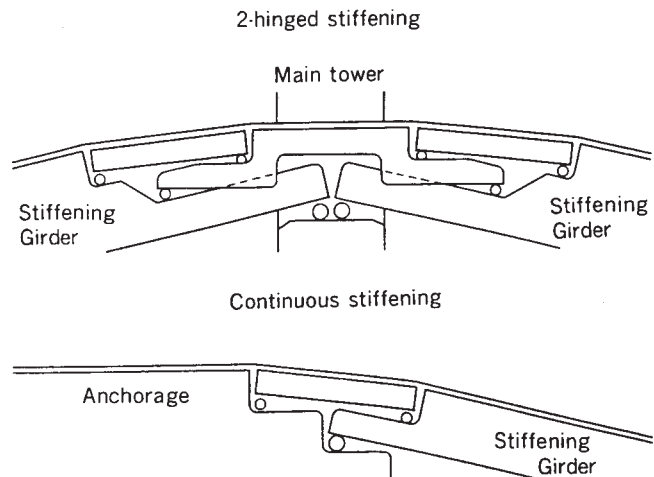

Figure 20. Expansion joint to accommodate changes in slope (Diagram by HSBA).

joints must accommodate longitudinal movement. A schematic of the railway expansion joint system that can accommodate movement as large as 1.5 m (5 ft) is shown in Figure 21. This system is used between the end anchorage and the first team of the stiffening truss. The receiving girder and side girders are fixed to the anchorage. The transition girder has one end that slides on the anchorage while the other end rests on a beam of the truss. The insertion girder has one end free to slide on the anchorage while the other end rests on and moves with the transition girder. The rails are fixed to each girder using direct fastening devices. Half sections of rails are used on the side girders and on the insertion girders to allow for longitudinal movement. Guide rails are also provided to protect trains from derailment.

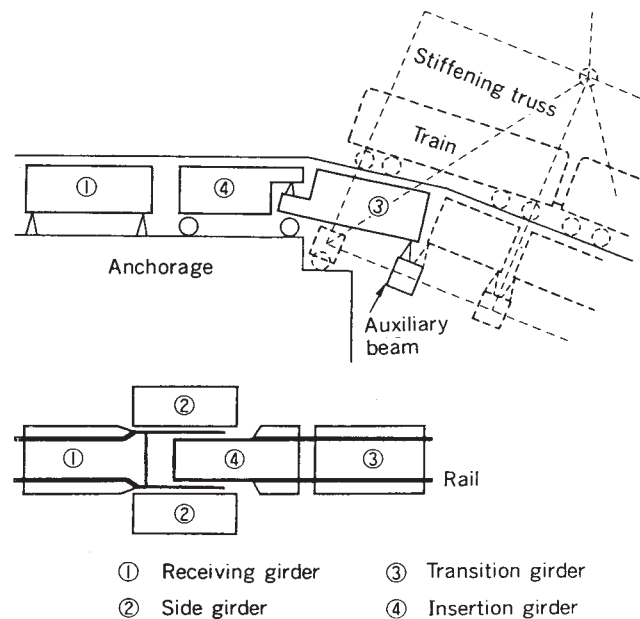

Figure 21. Railway expansion joint used on the Kojima-Sakaide Route (Diagram by HSBA).



### Cables

For suspension bridges and cable-stayed bridges on the HSBA routes, the following observations were made:

- Parallel strand cables were used for the main cables of the suspension bridges
- Lead/copper sockets were used to anchor the strands of the suspension bridges. A strand anchor on the Akashi-Kaikyo Bridge is shown in Figure 22.
- A black polyethylene pipe used for the outer layer of cable protection on the Tatara Bridge has a dimpled outer surface to reduce vibrations caused by wind and rain. A photograph of the pipe is shown in Figure 23.

The dimpled pipe surface may reduce or stop the vibrations that have occurred with smooth pipe used on some U.S. bridges.

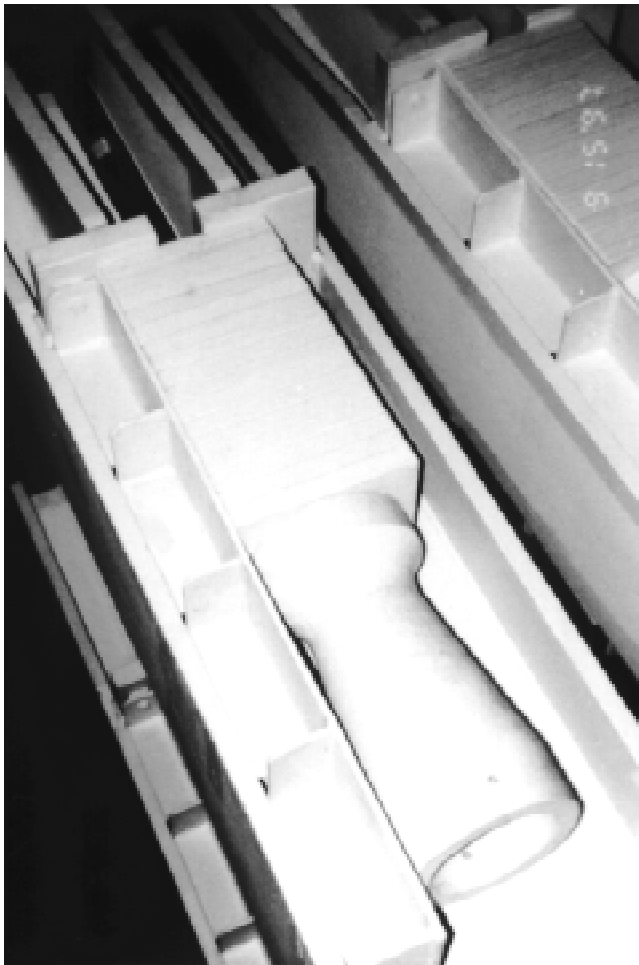

Figure 22. Strand anchorage on the Akashi-Kaikyo Bridge.



Figure 23. Dimple pipe used on stay cables on the Tatara Bridge.

### Pre-Manufactured Drainage System Within the Curb

Along the approaches to the Akashi-Kaikyo Bridge, deck drainage is handled in an innovative manner. The edge of the roadway surface is bounded by a pre-manufactured steel barrier curb. This curb has continuous perforations that allow the deck to drain into the curbs themselves. Inside the curbs are pipes that carry the drainage back to the abutments. The system is designed to allow routine maintenance and cleaning. Ponding is minimized because the drainage is a continuous perforated strip. Because the system is prefabricated and nonintrusive to the deck or to the superstructure, corrosion is minimized. The concept of this innovation is not used in the United States but is a simple one to introduce with either steel or precast concrete barriers.

### South Korea

In South Korea, the team was informed that, on a national basis, approximately 95 percent of the bridges are built with concrete. In the KHC system, approximately 80 percent of the bridges are concrete and, around the big cities, that amount drops to 40 percent. Most of the prestressed concrete bridges are precast on site and then post-tensioned using 12.7- or 15.2-mm (0.5- or 0.6-in.)-diameter strand sys-

tems. This is the opposite of U.S. practice where most concrete bridges are plant produced with 12.7-mm (0.5-in.)-diameter strand. Steel bridges are becoming more competitive in Korea as steel costs are becoming less and labor costs for concrete construction are increasing.

In the past, it was estimated that steel and concrete bridges would have design lives of 100 and 50 years respectively. Today, as a result of the truck traffic weight and volume, these estimates have been arbitrarily reduced to 50 and 25 years, respectively. The engineering basis for the revised numbers was not provided. KHC has a policy that permits the development of alternate designs but has limited experience at doing this. Contractors may also propose alternatives. Design of concrete slab bridges, steel bridges, and bridge details is standardized. It was estimated that approximately 60 percent of structural calculations and 30 percent of drawing preparations are automated.

The road construction budget in South Korea has increased by approximately 19 percent per annum over the past 5 years. Despite this increase, further expansion is needed to keep pace with growing demand. In the past, approximately 90 percent of the funding was derived from oil and gasoline taxes. Alternative funding policies are being developed for the future. Taxes on vehicle purchase and registration will be reduced and a special excise tax on oil will be raised. Other capital will be raised through the use of government bonds, private funds, new taxes on tires and lubricating oil, and private capital investments. Generally, private sector finances are expected to be about 60 to 70 percent of the project amount with the government providing the balance. For public road construction projects, the Korean government provides the land to the private sector. The new Incheon Airport Expressway project is the first to use private capital.

Designers are generally selected by the client through a process of prequalification and evaluation of subsequent proposals including costs. Designers for large projects are selected on the basis of prequalification and public bids. Excellent performance by a designer can lead to the designation of "Excellent Contractor" by MOCT. This distinction results in additional preference in the prequalification evaluation. Excellent Contractors also have the opportunity to take part in limited competition projects. On the other hand, designers that make a serious error receive demerits in prequalification.

The issue of punching shear failures in concrete decks was also raised in South Korea. The Korea Institute of Technology reports that cracks occur as a result of drying shrinkage. These cracks further increase as a result of traffic loads and penetrate through the deck thickness. Leaching of the concrete and corrosion of the reinforcement then occur, leading to a punching shear failure. Some decks have failed in this manner.

In construction, slip forming is often used for piers and barriers. On-site steam curing of concrete is performed. Pre-flexing of steel beams before the concrete deck is cast is

used for deflection control. Quality control for materials is achieved by inspection prior to materials arriving on site.

Construction of each tower foundation for the Youngjong Bridge was being performed using pneumatic caissons, six remote-controlled excavators and closed-circuit television from one control room, shown in Figure 24. Instrumentation is provided to measure water levels, current speed, caisson elevations, and tilt. Alignment of the caisson was controlled by water ballast and controlled digging. The bridge is being built by an 11-member international consortium.

The collapse of the Sung-Su Grand Bridge over the Han-Gang River in 1994 was thought to be the result of fatigue cracks that grew to a critical size and the members fractured. No detailed information on the failure analysis was obtained. According to KHC, no other instances of serious damage caused by fatigue have been reported. However, there have been instances of fatigue fracture and corrosion of secondary members. It was reported that analyses of fatigue-sensitive parts of steel bridges have been made since collapse of the Sung-Su Grand Bridge. It was also indicated that quality control of welding has been improved. The KHC personnel indicated that they are interested in increasing the toughness specifications for their bridge steels, but they do not have sufficient information yet to proceed.

## Taiwan

According to the Taiwan Area National Freeway Bureau annual report for 1996, the Bureau owns 166 bridges over water, 121 overpasses, 240 underpasses, 14 aqueducts, and 2 viaducts. The team understood that at the national level, approximately 95 percent of the bridges are concrete and at the municipality level, there are more steel bridges. Steel bridges are typically 30 percent more expensive than concrete bridges. Steel box beams are often used where the



Figure 24. Control room for excavation in pneumatic caissons.

horizontal radius is small. They are also preferred for aesthetic reasons. Pre-tensioned girders are not popular in Taiwan because span lengths and shipping lengths are not compatible. Maximum shipping lengths are 32 to 35 m (105 to 115 ft) and 4-m (13-ft)-wide box beams are often shipped at night to avoid further congestion on the highways.

During design, alternative systems are considered. Contractors may propose alternative construction methods before the bidding date. These methods are checked by the agency's engineer before bidding. If acceptable, the contractor may then bid a price based on the alternative. If several contractors bid alternative methods, the bid date may be extended to allow time for the designer to check the alternatives. The benefit to the agency is a lower price for the alternative. The benefit to the contractor is success in obtaining the project. This bidding system differs from that in the United States where alternative methods are reviewed after the bidding date. Currently, consideration is being given to a law that will split any savings equally between the agency and the contractor. Contractors are required to provide a 1-year warranty after final checking in the field.

In response to specific questions about design, the team learned the following:

- On concrete box girders, a 10°C (18°F) straight line thermal gradient is used.
- Deck thickness varies with span with a minimum thickness of 22 cm (8.7 in.). With steel box girders, design is based on AASHTO Specifications and deck thickness at webs is 40 to 50 cm (16 to 20 in.).
- Deck overhangs are typically 1.5 m (5 ft) but on the new freeway bridges the overhangs are as much as 3.5 m (11.5 ft).
- On box girder bridges built by the balanced cantilever method, the two cantilevers are jacked apart before the mid-span closure placement is made. This reduces the effects of forces caused by creep and shrinkage.
- Transverse post-tensioning of the deck is not used.

The Taiwanese reported concrete bridge deck cracking from truck overloads. These cracks occur in the longitudinal direction adjacent to the webs. They also reported deck deterioration caused by carbonation. In general, the only admixtures used in the concrete are for air entrainment. As a result, the concrete generally does not have a specified compressive strength greater than 34 MPa (5000 psi), although a compressive strength of 41 MPa (6000 psi) was used on the Hsichih-Wuku widening project.

During construction in urban areas, great care is taken to not interfere with traffic flow on the existing system. Methods that have been adopted include erecting above freely moving traffic and use of the balanced cantilever method of construction with the out-of-balance moment being taken by the pier during construction. The latter method has led to the procedure in which the cantilevers are alternatively advanced with only a half-length of segment out of

balance. This is achieved by casting a half-length segment at the beginning of one of the cantilevers. It was also noted that end spans were constructed using form travellers and the cantilever method. A temporary pier was provided near midspan to allow the cantilevering to continue to the abutment. Hydraulic jacks were installed between the temporary pier and the box girders to adjust for any settlements. This technique eliminated the need for continuous shoring that is frequently used in the United States.

During the site visit, it was observed that vertical mechanically stabilized wall systems, as shown in Figure 25, are used to heights of 15 m (50 ft). Galvanized metal straps are used to anchor the precast concrete teams. It was also observed that steam curing of bridge girders is used on site to obtain higher initial strength. This is probably essential since most concrete is site cast.

On the Hsichih-Wuku widening project, a technique described as the reverse circulation drilled pile method was used. In this technique, water is pumped into a hole and mud removed by suction from the bottom of the hole. After placement of the tremie concrete, grout is pumped between the bottom of the tremie concrete and the supporting soil.

While visiting the Kao-Ping River Bridge, the team observed an innovative foundation practice. To speed construction, 1.3-m (4.25-ft)-thick conventionally reinforced concrete slurry walls were constructed 37 m (121 ft) to rock in a rectangular shape surrounding the plan view of the tower. Excavation was then made to a depth of 7 m (23 ft) within the confines of the slurry walls. Reinforcing steel was tied into the walls to create a 4-m (13-ft)-deep table top to transfer tower foundation loads to the slurry walls. The remainder of the area was backfilled. No further foundation preparations were necessary at the tower location. This allowed for a relatively rapid, high-capacity foundation for the bridge tower. The team could not identify a similar application in U.S. bridge building practice.



Figure 25. Mechanically stabilized earth wall.

## Recommendations on Design and Construction Practices

Based on the above observations, the following topics are recommended for further evaluation and possible application in the United States:

- Research on punching shear failures from concrete fatigue.
- Bolted connections for earthquake resistance.
- Mechanical damping devices to control vibrations of steel towers.
- Forced vibration testing on completed bridges to determine actual natural frequencies and damping characteristics.
- Special railway expansion joints for flexible long-span bridges.
- Dimple pipe for exterior of stay cables to reduce oscillations.
- Pneumatic caissons with remote control equipment for underwater construction.
- Balanced cantilever construction with alternate segments offset by 1/2-segment length.
- Full cantilever erection for end spans of balanced cantilever bridges.
- Slurry-wall construction for tower foundations.

In addition, the team recommends that relevant sections of the HSBA specifications be translated into English.

## MATERIALS, FABRICATION AND JOINING TECHNIQUES

### Japan

#### *Special Concretes*

For the cable anchorages of the Akashi-Kaikyo Bridge, HSBA used a self-levelling highly flowable nonsegregating concrete. The concrete mix included a low-heat cement, limestone powder, superplasticizer, and 40-mm (1.6-in.) maximum size coarse aggregate. The concrete was specified to have a flow of 500 mm (20 in.), air content of 4 percent, and a 91-day compressive strength of 30 MPa (4350 psi). For hot weather concreting, the water was cooled to 2° C (35° F), the fine and coarse aggregates were cooled by spraying with chilled water, and the coarse aggregates were conveyed in cool water on a belt conveyor. By these means, the initial concrete temperature was held to 13° C (55° F) to reduce the amount of cracking in the anchorages.

For the underwater concrete of the tower foundations of the Akashi-Kaikyo Bridge, a special nonseparating concrete was used. The concrete contained a high-range water-reducing admixture to achieve flowability and an anti-washout admixture to obtain viscosity. An anti-washout

admixture is available from at least one supplier in the United States but is not extensively used. The concrete for the Akashi-Kaikyo Bridge foundations was produced in a floating batch plant.

Despite their advances in concrete technology, HSBA has discontinued the use of the lightweight concrete because it is considered less reliable than normal weight concrete. In the past, there have been problems in placing and vibrating lightweight concrete. In contrast, the use of lightweight concrete in high seismic regions is increasing in the United States.

#### *19-Wire Prestressing Strands*

The Japanese have developed 19-wire prestressing strands with diameters of 17.8, 19.3, 20.3, and 21.8 mm (0.70, 0.76, 0.80, and 0.86 in., respectively). The strands consist of two concentric layers of wire wrapped around a center wire. The wire diameters in the two layers are different. Each concentric layer consists of nine wires. The strand has a specified minimum strength slightly less than Grade 270 strand. The largest strand has a minimum breaking strength of 3.1 times the strength of a 12.7-mm (0.5-in)-diameter Grade 270 strand. The strands are listed in JIS G 3536 Uncoated Stress-Relieved Steel Wires and Strands for Prestressed Concrete. According to HSBA, the 19-wire strand is used for transverse post-tensioning of bridge decks. The strand has potential applications in the United States with high-strength prestressed concrete beams.

#### *High-Strength Steel Wire*

A high-strength silicon steel wire with tensile strength of 180 kgf/mm<sup>2</sup> (256 ksi) has been developed for use in suspension cables in long span bridges. The cable was first used in the Akashi-Kaikyo Bridge. HSBA reported that the bridge design would have required four main cables with traditional strength wire. The high-strength silicon wire, in combination with a lower factor of safety for the cable, allowed the use of only two cables, thereby significantly reducing the weight and cost of the structure. The Japanese indicated that they have researched the corrosion fatigue and stress corrosion cracking performance of this wire and found it to be as good as traditional wire. This wire may not have an immediate market in the United States, but it may be important in the future for very long span structures.

#### *Quality of Japanese Steel*

In prior meetings with the Japanese, it has been implied that the steels produced in Japan are higher quality than those produced in the United States. This statement cannot be proven or disproven based on information obtained in



this scanning tour. The Japanese specifications do not seem to be more stringent than the U.S. specifications, except for the case mentioned below. During the visit to Nippon Steel's Kimitsu Works, it was indicated that the vacuum degassing process has been applied to all steels used in bridge construction for at least 13 years. This process reduces the amount of hydrogen and other gasses that are trapped in solution in molten steel. Presence of high amounts of these gasses can lead to weldability and toughness problems. This process is available in the United States but has not been commonly used during production of structural steels because it increases cost. Because degassing does improve the quality of steel, this may be one reason to support an alleged quality difference between Japanese and the U.S. steels. No information was obtained concerning the price difference between Japanese and U.S. steels.

#### *High-Performance Steels (HPS)*

There appears to be a strong interest in Japan to use steels with high-performance attributes for bridge construction. The reasons are to produce structures with lower cost and to produce more durable structures with a lower life-cycle cost. However, it is not clear what percentage of the new steel bridge market is currently using HPS. There is no absolute policy requiring its use. The current highway specifications allow for the use of steel with a yield strength up to 570 MPa (83 ksi). One recent change is that the bridge specifications no longer allow steel to be specified under the JIS SM 400A specification. This is essentially the same as the ASTM A36 specification used for rolled shapes. This means that U.S. steel producers would not be able to market A36 steel for bridges in Japan.

Nippon Steel Corporation appears to call their entire steel product line for bridges "high performance steel." Since there is no clear definition of what constitutes high performance, this may or may not correspond with what is called HPS in the United States. For instance, Nippon Steel lists SMA 490W as high performance while the corresponding product in the United States, ASTM A588, would not fall under this definition. Several products from Nippon Steel that are not commonly used or are not available from U.S. steel producers are described in the following sections.

#### *Weathering Steel With Chloride Ion Resistance (SMA 490CW-MOD and SMA 570WQ-MOD)*

This product is essentially equivalent to U.S. steel grades A709-50W and 70W, respectively, with the exception that the nickel content is increased from about 0.3 percent to about 3 percent. Similar steels are available in the United States under the ASTM A710 specification, but steels meeting this specification are not currently allowed by AASHTO for use in bridges. With the additional nickel,

this steel can no longer be considered a "weathering" steel that depends on development of a rust patina for corrosion resistance. This steel is actually a low-grade stainless steel and it might be more proper to call it corrosion-resistant steel rather than weathering steel. Nickel is a very expensive alloying element. Therefore, the cost of this steel is expected to be significantly higher than weathering steel but not as expensive as a true stainless steel.

There may be a potential application for this product to allow unpainted bridges in environments where traditional weathering steel is not considered suitable. Such applications include coastal areas, wet areas, and areas where superstructure elements are expected to be exposed to significant amounts of road salt such as under expansion joints. The added cost of this steel may be justified in many circumstances when compared to the cost of painting and maintenance over the life of a structure.

#### *Titanium and Stainless Clad Steel Plate*

This product has a thin layer of titanium or stainless steel metallurgically bonded to the surface of a high-strength, low-alloy (HSLA) steel plate during the rolling operation. The result is a structural steel plate with extremely high corrosion resistance at a much lower cost than a solid corrosion-resistant plate. The Japanese have used titanium clad plate for corrosion protection of the steel piers supporting the Trans-Tokyo Bay Highway. A 5-year field test showed the titanium cladding was effective in preventing corrosion in the tidal and splash zones of the bridge. The cost of the cladding systems was not made available to the team, but it can be surmised that they are expensive. Because of the expected high cost, it is doubtful that limited use in bridge structures could justify the cost to develop such products in the United States. It was not determined how much of this product has been used in Japan.

#### *Weathering Steel*

The use of weathering steel has been somewhat limited in Japan. It has only been used in mountainous regions and corrosion-free places. The Japanese have an interest in using increased amounts of weathering steel to avoid the high costs of painting. However, they have a concern that current weathering steels may still continue to corrode in many parts of Japan.

A new product is being developed that may have the potential for improving the performance of weathering steel. Sumitomo Metal Industries, Ltd., is working on a primer coating for weathering steel that can improve the development of a stable rust patina. This coating appears to be applied in a manner similar to a shop-applied primer coat for painted bridges. It appears that elements from the primer combine with elements from the steel to form an enhanced



rust patina on the surface. Researchers at PWRI indicated that there may be two significant advantages to this product. It promises to eliminate initial substructure staining that has been a problem with weathering steel use in some cases and it promises to help stabilize the patina and reduce the rate of corrosion for the weathering steel. This product is still being researched at PWRI to verify its beneficial attributes.

If this product works as well as is hoped, it could have a significant impact on the economy of steel bridge construction in many parts of the United States. There are still many authorities in the United States who are not using weathering steel even though it can be economical. Concerns relate to the corrosion rate and aesthetics related to the staining problem. If this product, or some other product, could be proven to work, it should pave the way for increased use of weathering steel.

#### *Vibration Damping Steel Plate*

This product, with a trade name of Vibless-Plate, consists of a 0.15- to 0.3-mm (0.006- to 0.012-in.) layer of visco-elastic resin sandwiched between two 2.3- to 10-mm (0.09- to 0.39-in.)-thick steel plates. In this plate, the shear deformation of the visco-elastic resin layer caused by the vibration has the effect of damping the vibration. The product was developed for use in structural members to reduce the noise emitted from elevated highways and rail lines in dense urban areas. This is a significant problem in densely populated cities in Japan where elevated roads and railways are close to occupied buildings.

#### *Tapered Thickness Plates*

The Japanese indicated that some bridges have been built with tapered thickness plates. These plates are rolled so that the thickness continuously changes along the plate length, allowing designers to continuously vary the girder section properties to match the required section properties. This results in an efficient design with reduced flange splines. Discussions indicated that the economy of using tapered plates is questionable. Nippon Steel Corporation indicated that they do not like to roll tapered plates as it disrupts their normal production procedures. Because the benefit of tapered plates is not immediately apparent, this item should probably not be recommended for immediate implementation in the United States. The experience of both the Japanese and Europeans should be monitored to see if a clear advantage becomes apparent.

#### *Thermo-Mechanical Control Processing (TMCP)*

In the Nippon Steel Corporation Plant, thermo-mechanical control processing equipment was being used in the roll-

ing mill. TMCP consists of applying accelerated cooling or direct quenching to the plates during the rolling process, resulting in plates with higher strength and toughness without increased alloy content. TMCP also allows the production of plates with lower carbon equivalent numbers, a property that greatly improves weldability. The result is that plates with yield strengths greater than 345 MPa (50 ksi) can be produced on-line without the need for off-line quenching and tempering. Also, on-line processing does not limit the length of plate that can be produced. The use of TMCP has allowed HSBA to weld 14-mm (0.55-in.)-thick 780-MPa (113-ksi) ultimate strength steel with only 50° C (122° F) preheat and no interpass control. A large proportion of the steel in the stiffening truss of the Akashi-Kaikyo Bridge is 780-MPa (113-ksi) tensile strength steel.

Conventional off-line quenching and tempering can be used to obtain similar steel properties as TMCP, but the process is more expensive to perform and only a few U.S. fabrication shops apply this technology to bridge construction. Current off-line quenching and tempering in the United States limits plate lengths to about 15 m (50 ft). This can increase the number of welded splines required to fabricate a bridge girder thereby increasing cost. The advantages of TMCP have been known to both the FHWA and U.S. Navy for many years, but the U.S. steel industry does not yet have this capability in their facilities. Introduction of TMCP capability, or similar technology, into the United States hinges on the willingness of the steel companies to make the necessary capital investments. This should begin to happen in the near future. Once this capability becomes available, it should improve the quality and cost of HPS in the United States as it has done in Japan.

#### *Other Products*

Nippon Steel Corporation has also introduced a number of specialty steel products targeted for specific applications. There is a special Hi-Arest Steel that is designed to arrest brittle crack propagation and stop progressive damage in ship and tank structures. A lamellar tear-resistant steel is available mainly for building columns and other special "high restraint" applications. There is also a special steel designed to allow high heat input welding for building use. In addition, the Japanese have developed a fire-resistant steel for use in buildings. This steel shows a slower rate of strength loss with increasing temperatures compared to the normal steels. None of these products have been marketed for use in bridge structures in Japan.

One other item of note is that the Japanese have special requirements for steels that are subjected to cold forming operations. The toughness of the steel is specified depending on the radius of the cold form bend required. Smaller radii require higher toughness to prevent cracking. It is not clear how much this steel is used in bridges in Japan. There is currently little use of cold forming in

bridge structures in the United States, but this may change in the future.

#### *Quality Control in Fabrication*

During the visit to the Yokogawa Bridge Corporation, it was noticed that greater importance was placed on quality control than in the average shop in the United States. Full-sized templates were created using a computer attached to a very large plotter. There appeared to be a lot of double checking of layout and tolerances during the hole drilling and fit-up operations. Even when computer-controlled drilling equipment was used to drill holes automatically, the plates were first laid out on separate equipment as a check.

#### *Implementation of CADD/CAM Technology*

The Chiba Plant of Yokogawa Bridge Corporation uses computers to generate the shop drawings and layout templates for structures fabricated in its shop. The Chiba Plant had not implemented a direct interface between the CADD system and the systems used to program the automatic cutting and drilling equipment on the shop floor. Yokogawa indicated, however, that some of their other fabrication plants are already using such an interface. There are a few U.S. shops that have experimented with this technology, but none have it in everyday use. Further development and implementation of this technology should be strongly encouraged in the United States to improve the fabrication efficiency of steel bridges.

#### *High-Heat Input Welding*

Large single pass, high-heat input welds were routinely observed in the site visits to the Chiba Plant and the HSBA bridges. Both the submerged arc welding (SAW) process and the gas-metal-arc-welding (GMAW) process appeared to be used routinely. The twin parallel arc process appears to be routinely used for bridges, as is common practice in many U.S. fabrication shops.

The big advantage to high-heat input welding is that it speeds up the fabrication process. The welds observed at the Chiba Plant were similar in size to those produced by the electroslag process in the United States. Both processes are currently not allowed in bridge work in either country because it is difficult to get adequate toughness for bridges. In the United States, research has concentrated on improving the electroslag process, while in Japan, they appear to be researching SAW and GMAW processes. This may be an issue where future information exchange would benefit both countries.

#### *Use of Computerized Assembly and Testing System (CATS)*

One of the standard requirements in U.S. practice when fabricating complex bridge components is to have these components shop assembled to ensure the ease and quality of the eventual field erection. Consequently, large lay-down areas must be reserved for assembly of these members and additional costs must be incurred for storage before final assembly. Many U.S. fabricators who do hand lay-out of holes need to drill or ream the holes in place when the structure is shop assembled. An additional factor that complicates the process is the limitation of delivery of materials from more than one fabrication shop.

The Yokogawa Bridge Corporation has developed a new computerized system to simulate erection of complicated structures and to eliminate the need for shop assembly of bridges. CATS uses photogrammetry methods with four cameras to take 3-D pictures of each element. Long members such as main girders and stringers are carried through the visual field of the cameras on a special carriage as shown in Figure 26. Vertical and horizontal movements and angular rotations are measured by a laser system and electronic levels, respectively. Finally, the shape and dimensions of the members are obtained by linking the data from the cameras and the other measuring devices. The measurement accuracy is reported to be 1 in 10,000 and a 15-m (50-ft) length can be measured in 50 min including loading and unloading time. The members are then 'shop assembled' in simulation on the computer screen using software developed for that purpose. Any corrections that need to be made to the members are identified.

After processing the recorded data, the actual measurements are compared with the design data to identify production errors. This innovation removes the need for shop assembly, while ensuring accuracy. In addition, information, such as camber and joint widths for assembling the bridge at the construction site, is developed.

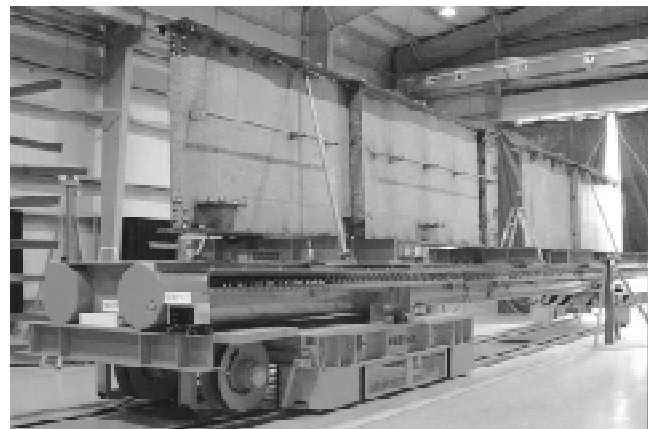

Figure 26. Computerized Assembly and Testing System (CATS).

In the application of CATS to a 100-m (328-ft) span steel arch bridge, the measured length of the completed structure was within 4 mm (0.15 in.) of the design length. Measured errors in vertical cambers of the stiffening girder were approximately one-half of the allowable range of 25 mm (1 in.). The computer simulation allowed the thickness of shim plates for the suspended cables to be determined accurately. This eliminated the need to adjust the shim plates at the site. The time required for the fabrication process was reduced by approximately 2 months. Implementation of a computerized erection system could result in significant cost savings in the fabrication of steel bridges. This will be especially true for box girder bridges with complex curves and geometry.

### *Field Welding*

Field welding is routinely used during construction of the bridges on the HSBA routes. The segmental sections of the steel box deck sections on the suspension bridges and cable-stay bridges all had a full penetration closure weld connecting the top deck plates together. HSBA indicated the welds were made in the field using the GMAW process. The welds appeared to be one-sided and made with a single pass. The specification for the root gap is shown in Figure 27. The root opening is specified as 0 and 10 mm (0 and 0.39 in.) with a target value of 3 mm (0.12 in.). The plate thickness was about 25 mm (1 in.). Conversations with Professor Miki indicated that fatigue and toughness testing showed these welds were suitable for their intended purpose.

### *Removable Back-Up Bars for One-Sided Welding*

HSBA makes use of steel bridge decks for all its major bridge projects. These are orthotropic bridge decks field

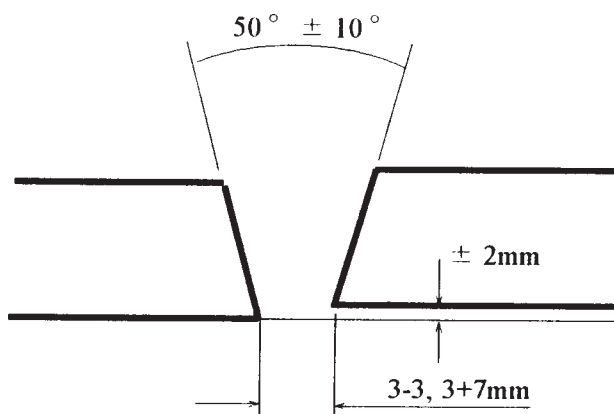

Figure 27. Specifications for the root gap of steel deck plates for on-site welding (Diagram by HSBA).

welded from one side only. Among the challenges with these field welds and all sizable welds that use conventional steel backer bars is the issue of locked-in stresses. Conventional steel back-up bars are tack welded into place. As the molten weld metal is deposited in the joint opening, the heat combined with the restrictions imposed by the tack welded back-up bars cause concern for locked-in stresses. If left in place, the back-up bars form an initiation site for fracture and fatigue. On the HSBA bridge decks, removal would require overhead grinding and welding to finish the bottom of the weld. A non-metallic back-up bar greatly simplifies this process. The current alternative in the United States is to use ceramic back-up bars. These are seldom used based on perceived high costs.

For HSBA bridges, a temporary, nonmetallic back-up bar was attached to the bottom of the deck plate using adhesive strips on the bar. The bar has a concave surface on the side attached to the deck to allow some over-reinforcement on the bottom side of the weld. The bar can be easily removed for inspection of the weld after completion. The specific materials used in the bar were not identified. However, the back-up bar used in Japan appeared to differ from the ceramic bars available in the United States and it was implied that the cost of the bars was much lower. Potentially, the use of a similar back-up bar with adhesive strips in the United States can provide cost-effective quality improvements in U.S. welding processes. The Nippon Steel Welding Products & Engineering Co., Ltd., markets the bars in Japan. Samples of these bars should be obtained and evaluated using U.S. welding procedures.

### *Use of Four-Sided Truss Elements that Transition to I-Sections*

HSBA uses innovative truss elements in their stiffening girders. These elements are fabricated as four-sided boxes or tubes. However, toward the ends of the sections, two of the four sides are transitioned into a single web section and the other two sides continue through to create a wide flange I-section that can be connected on two sides. The two sides greatly simplify the bolted connections at team points where multiple members come together. A connection is shown in Figure 28. Additionally, the Authority's research has demonstrated that improvements in fatigue resistance are provided by the smooth transitions. The smooth lines also minimize the build-up of debris and improve corrosion resistance. The hollow tube section is closed completely, minimizing corrosion concerns. This innovation has the potential for U.S. application in new structures and in the replacement of existing truss elements that utilize box sections created from lacing bars. This technique may have application in structures other than trusses.



Figure 28. End connection of tapered members.

### *Bolted Connections*

In Japan, the use of twist-off and blind bolts is accepted practice. In the United States, these are often allowed as contractor options. The benefits of the greater use of blind bolts (one-sided bolts) include the ease of connection of hollow tube sections. Currently, the complex connections associated with these hollow sections limit their acceptance in U.S. practice. Additionally, more common use of twist-off bolts would ease quality assurance concerns and speed steel erection. These are U.S. innovations that seem to be more accepted overseas than within U.S. practice. On HSBA bridges, the turn of the nut method is used with high-strength bolts to monitor bolt installation.

### **South Korea**

The majority of steel bridges around the Seoul area use multiple rectangular box girders. Very few I-girder bridges were observed. Most steel bridges had more bolted splices than used in the United States. The splices were occurring about every 8 m (26 ft) along the length of the structures. It was suggested by KHC that 8 m (26 ft) is about the maximum practical shipping length by highway. It is not known what steel plate lengths are available in South Korea nor was any information obtained on welding practice. It is not known whether they prefer to bolt or weld plate connections in the fabrication shop.

### *Thermo-Mechanical Control Processing (TMCP)*

TMCP is available to at least one steel producer in South Korea. POSCO developed TMCP steel products in 1991 to meet the market demand for a steel with higher yield strength and enhanced weldability. The Koreans reported that TMCP results in a 10 percent increase in yield strength and produces a steel with excellent welding properties, seismic re-

sistance, and lamellar tearing resistance. The steel has been used in buildings but has not yet been used in bridges.

### *Weathering Steel*

Weathering steel is available in South Korea from two suppliers (POSCO and Bethlehem Steel). Prior to 1994, there was little demand for the product, but its usage has been increasing and is expected to exceed 10,000 tons per annum. The most likely demand will be for a weathering steel with a yield strength of 483 MPa (70 ksi). Research is underway to achieve weathering steels with higher yield strengths. In July 1997, five uncoated weathering steel bridges had been completed in South Korea and eight more bridges were under construction.

### *High-Strength Steels*

High-strength steels have been developed to reduce the weight of steel structures in tall buildings. They have not yet been used in bridges. The Koreans classify their product into the following four categories:

- High tensile strength achieved with low alloy content.
- High tensile strength achieved by heat treatment.
- Techniques to achieve finer crystalline structure.
- Hardening techniques by cold working.

Steel is classified by tensile strength of 490 and 588 MPa (71 and 85 ksi). The 490 MPa (71 ksi) steel was reported to have excellent characteristics for welding, notch fatigue strength, workability, and corrosion resistance.

### *Fire-Resistant Steel*

The Koreans also reported on fire-resistant steel for buildings in which the fire-resistant coating can be reduced by 1/3 to 1/2 compared to the normal coating. This product is currently awaiting certification for use by the MOCT.

### *Other Information*

During the visit to the POSCO Center Steel Gallery, a display illustrated that POSCO has developed an artificial intelligence model for blast furnace operation and a high level of automation in steel production. It was also noted that continuous casting and vacuum degassing are used. The extent that these processes are used in production of steel for bridges was not determined.

It was learned from discussions that some fabricators have automatic cutting and drilling machines and that some



proprietary systems have been developed. Generally, the smaller companies do not have automated equipment.

Spirally welded steel pipe was observed being used for drilled foundations. No information was obtained about the properties of this type of pipe.

### Taiwan

Structural steels used for bridge production in Taiwan are based on ASTM Specifications. Steels conforming to ASTM Designations A 36 and A 572 are used for most bridges. A few bridges have been built with steels conforming to ASTM A 588, but were painted.

For fabrication, it was reported that numerically controlled equipment is used for cutting and drilling. For fabricated sections with 50-mm (2-in.)-thick flange plates connected to the web with penetration groove welds, it was found that lamellar tearing occurred in the flange. The tearing was attributed to through-thickness shrinkage from the groove weld.

Prefabricated sub-assemblies are welded on site using both SAW and GMAW processes. With the GMAW process, shielding is required to block the wind which might interfere with the CO<sub>2</sub> shielding gas.

### Recommendations on Materials, Fabrication and Joining Techniques

On the basis of the above observations, the following technologies are recommended for further evaluation and possible application in the United States:

- Nonsegregating flowable concretes.
- Nonseparating tremie concretes.
- 19-wire prestressing strand.
- High-strength silicon steel wire.
- Steels containing a higher percentage of nickel to improve corrosion resistance.
- Vibration damping steel plates.
- Increased use of TMCP or similar technology.
- Computerized assembly and testing system (CATS) for steel components.
- Nonmetallic removable back-up bars for one-sided welding.
- Truss elements that taper to I-sections at the end connections.

### BRIDGE PROTECTION STRATEGIES

This section discusses a variety of protection strategies for suspension cables, structural steel members, steel reinforcement, and steel bridge decks as observed in the three countries. The limited use of de-icer salts is a factor

that influences the bridge protection strategies in these countries.

### Japan

#### High-Strength Steel Wire

HSBA does not consider corrosion-fatigue of the high-strength silicon wire to be any worse than corrosion fatigue of conventional cable wire. They attribute part of this to the lower ratio of live load to dead load that occurs in long-span structures and to their technique of drying the air inside the cable as described below.

#### Cable Wrapping Wire

On the Kurushima Bridges, a wrapping wire with an S-shaped cross section, developed by Nippon Steel Corporation, will be used to wrap the main cables. The cross section of the wire, as shown in Figure 29a, is designed so that the two legs of the S-interlock to produce the pattern shown in Figure 29b. The interlocking provides a tighter seal against moisture penetration compared to wrapping with conventional wire having a circular cross section. The interlocking is also expected to reduce cracking of the exterior coating.

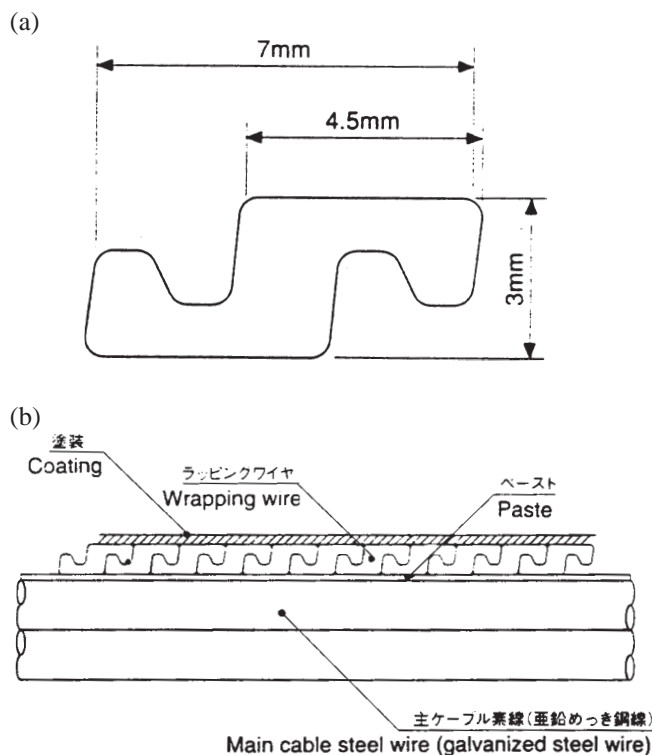

Figure 29. Interlocking wrapping wire (Diagrams by Nippon Steel Corp). (a) Cross section of wire; (b) Cross section of cable.



During installation on the cables, the advancing speed of the wrapping machine is synchronized with the wrapping speed to ensure secure interlocking.

#### *Air Injection System for Main Cables of Suspension Bridges*

The latest HSBA system for corrosion protection of the main cables of suspension bridges consists of the injection of dry air into the main cable interior. The goal is to keep the humidity level inside the cable below 40 percent. This is the level that their research indicates will prevent corrosion of the main cable wires. The system is used on the Akashi-Kaikyo Bridge, as shown in Figure 30a, and will be used on the Kurushima Bridges. A schematic of the installation is shown in Figure 30b. Installation of the system involves the following steps:

(a)

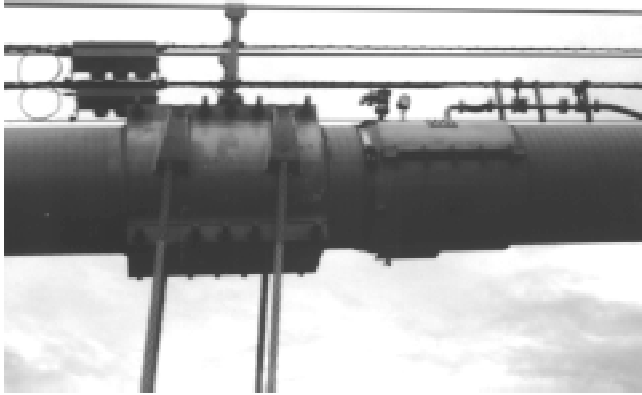

(b)

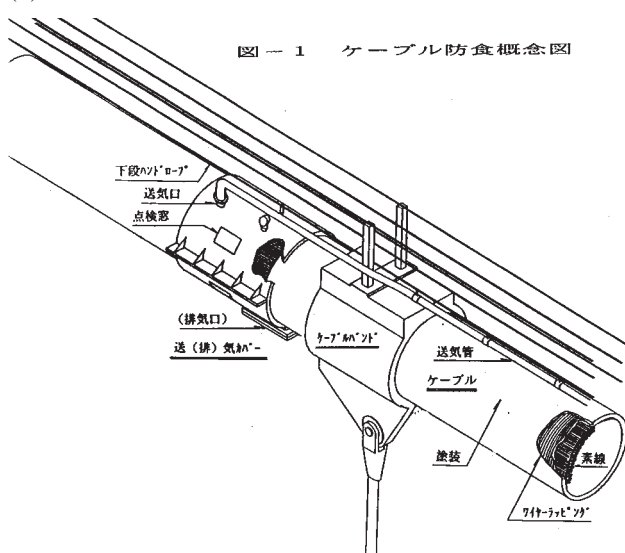

Figure 30. Air injection system for cables. (a) Akashi-Kaikyo Bridge; (b) Schematic (Diagram by HSBA).

- Weld the wrapping wire at two points to limit the unwrapped area.
- Cut and remove wrapping wire between weld points.
- Drive wooden wedges into the cable to allow access to the center of the cable.
- Install moisture meters to continuously monitor the humidity within the interior of the cable.
- Install permanent pipes to allow injection of air into the interior of the parallel wire strand mass. HSBA tests indicate that injection is needed at every 200 m (656 ft) of cable length. However, they plan to install injection ports approximately every 110 m (330 ft). The interior volume of a main cable consists of upwards of 20 percent air. No additional longitudinal means is required to transmit the injected dry air.
- Connect pipes to a supply of dry air.
- Remove wedges.
- Re-wrap the exposed areas of cable with a neoprene wrapping material.

HSBA research indicates that only injection of dry air is necessary. Extraction of air is not necessary although the schematic diagram in Figure 30b includes an exhaust valve. HSBA's research also indicates that it takes from 20 to 75 days to reduce the humidity of the interior air to the 40 percent target level once injection begins. In addition to the use of this system on new suspension bridges that will not have any anti-corrosion paste installed, HSBA plans to retrofit suspension bridges that were constructed with an internal anti-corrosion paste. These built structures are quite similar to suspension bridges in service in the United States today. HSBA has adopted an active system to control corrosion as distinct from passive systems that have been used in the United States. Passive systems rely on protective materials to prevent moisture from penetrating into the cables.

#### *Hot Dip Galvanizing*

Many of the overpass bridges observed in Japan used hot dip galvanized steel members. The size of hot dip tanks in Japan allows for the use of this corrosion protection system. The size of these tanks was reported to be 3-m (10-ft) deep by 50-m (164-ft) long. This is considerably larger than tanks available in the United States today. The Japanese representatives indicated that they do not allow for double dipping of steel girders.

#### *Metallized Sprays*

PWRI has been working with an improved thermal spray system. The spraying units themselves have been made more portable. One unit can weigh as little as 36 kg (80 lb). The new thermal spray system uses considerably less heat. Evidence was presented to demonstrate that the

material can be safely sprayed over an unprotected human hand without pain. The primary innovation discussed, however, was the metal used for the thermal spray. Rather than using solely a zinc product that loses its effective galvanic protection system rapidly or an aluminum spray that mainly provides barrier protection, the Japanese advocate a 50:50 split of these two materials by volume. It is expected that this system offers the best alternative for thermal spray applications. At the present time, its use has been reserved for long-span bridges because of the high cost.

#### *Special Paint Primer*

In cooperation with major steel producers, PWRI has been testing and evaluating a significant improvement in corrosion protection technology. This technology is a new spray-on product that was referred to as “suspicious primer.” PWRI research demonstrated that the only fully stabilized weathering steel bridge in Japan contained 3 to 4 percent chromium steels. With that in mind, a spray-on primer product that stimulates the formation of the chromium steels was developed by one of their steel producers. This product was successfully tested by PWRI and sent to all major steel suppliers in Japan to have additional independent testing conducted. Over the last year, test results have been positive. The product would be used on all bridge steels, regardless of grade and chemical make-up. The product is commercially available from the Sumitomo Metal Industries, Ltd., as the “Weather-Act Method.” Successful usage of this product has the potential to enhance protection practices of steel bridges in the United States.

#### *HSBA Paint Systems*

For protection of their steel structures from corrosive sea environments, HSBA has developed long-life coating systems comprising either polyurethane or fluoro-polymer paints. The paint system is specified in the HSBA Painting Standard for Steel Bridges. This document, written in Japanese, was supplied to the team.

#### *Steel Reinforcement*

For corrosive protection of reinforcement in bridge decks, HSBA prefers to use 50-mm (2-in.) concrete cover rather than epoxy-coated reinforcement as used in the United States. The Japan Roads Association has published guidelines for the protection of road bridges from chlorides. These guidelines are reproduced in Table 4. For areas away from the coastline, the concrete cover values in Table 4 are less than are required by *AASHTO Specifications*. It was reported that de-icing salts are used primarily in the north of Japan but usage is not as heavy as in the United States.

Damage caused by chlorides is relatively small. In addition, concrete bridge decks have an asphalt riding surface. A waterproofing coat is provided between the concrete and the asphalt overlay. Details of this system were not available.

#### *Steel Bridge Decks*

The Japanese have many bridges with orthotropic steel decks. An asphalt system is used to protect the decks. Detailed information about the system was not obtained.

### **South Korea**

In South Korea, steel bridges are generally repainted every 7 years after cleaning to bare metal. In the past, inorganic zinc coatings were frequently used. A change to organic coatings is happening because of environmental concerns. Heavy duty coatings with a 25-year warranty from the manufacturer have been used. KHC does not have any weathering steel bridges, although there may be two or three owned by others in South Korea. On some bridges, the contractor provides a 10-year warranty on the whole bridge except for normal maintenance. The defects covered by the warranty are defined in the contract.

More than 90 percent of the bridges in South Korea have a concrete deck. Approximately 60 percent of the decks are reinforced concrete slabs. Their bridge deck protection strategies include attention to drainage systems, design and maintenance and use of preformed sheet membranes, and coating membranes or penetrating sealers. Recent changes in their deck design have included increasing the concrete strength from 240 to 270 kg/cm<sup>2</sup> (3410 to 3840 psi), increasing the amount of reinforcement in the longitudinal and transverse directions, and increasing the deck thickness. Deck thickness is selected based on deck span, span direction, end conditions, traffic volume, and degree of difficulty to repair. Minimum deck thickness is 22 cm (8.7 in.). There has been some use of epoxy-coated reinforcement.

Protection for post-tensioning tendons is provided by grouting when the tendons are inside the concrete. When tendons are external to the concrete, grease is used to protect the tendons.

### **Taiwan**

In Taiwan, a 7-year warranty is generally provided for painting of steel with 10 years on cable-stay bridges. Orthotropic steel decks are covered by 80 mm (3.2 in) of asphalt. All other bridge decks are covered with asphalt to improve rideability. The asphalt is replaced every 2 years.

Corrosion of reinforcement in bridge decks does not appear to be a concern in Taiwan as de-icing salts are not

TABLE 4 Japan Roads Association—guidelines for concrete cover

Minimum cover of reinforcing bar is shown in the table below and must be more than the diameter of the bar.

unit: mm (in.)

Level*	Superstructure			Substructure	
	Under-surface of deck	Girder		Beam	Column
		Pretensioned	Other		
I	50 (2.0)	50 (2.0)	70 (2.8)	70 (2.8)	70 (2.8)
II	40 (1.6)	35 (1.4)	50 (2.0)	50 (2.0)	50 (2.0)
III	30 (1.2)	25 (1.0)	35 (1.4)	35 (1.4)	40 (1.6)

For painted bars, use the Specifications for Highway Bridges as shown below.  
For painted concrete surfaces, use the Specifications for Highway Bridges.

## \*Levels by Regions

Regional Category	Region	Distance from shoreline	Level
A	Okinawa Prefecture	Above the sea or within 100 m (330 ft)	I
		Other	II
B	Coastline region of Sea of Japan between Hokkaido and Fukui Prefecture	Above the sea or within 100 m (330 ft)	I
		100 to 200 m (330 to 660 ft)	II
		200 to 300 m (660 to 985 ft)	III
C	Other	Above sea	I
		Within 100 m (330 ft)	II
		100 to 200 m (330 to 660 ft)	III

## Minimum Cover Given in Specifications for Highway Bridges

unit: mm (in.)

	Deck, Curb, Railing and Less than 10-m Slab Bridge	Girder	
		Precast	Other and More than 10-m Slab Bridge
Minimum Cover	30 (1.2)	25 (1.0)	35 (1.4)

used. Their primary concern is deterioration caused by cracking and carbonation. They indicated that their minimum deck thicknesses vary from 22 to 25 cm (8.7 to 10.0 in.) depending on span.

### Recommendations on Bridge Protection Strategies

Based on the above observations, the following topics are recommended for further evaluation and possible application in the United States:

- Wrapping wire with interlocking cross section.
- Dry air injection system for corrosion protection of cables.
- Flame or thermal spray metallizing.
- Special paint primer.
- HSBA paint system.
- Asphalt overlays for orthotropic steel decks.

### INSPECTION AND REHABILITATION PRACTICES

Inspection and rehabilitation practices varied in the three countries. The following sections summarize the information learned in each country.

#### Japan

In Japan, it was reported that a detailed inspection of their bridges is performed every 10 years. The primary inspection method used in Japan is visual. Other methods, such as dye penetrant, magnetic particle, and ultrasonics are applied in some cases.

HSBA informed the team that the wearing surfaces of their bridges are inspected every day. Overhead portions of structures receive a cursory visual inspection at the same time. HSBA performs three types of detailed inspections as follows:

- Regular inspections of the main structural members are conducted annually. The main girders, cables, towers, bearings, expansion joints, piers, and anchorages are checked for coating deterioration, concrete cracks, loose bolts, member damage, and other unusual appearances.
- Detailed or configuration inspections are conducted every 5 years and involve measurement of tower inclination, cable tension, vertical alignment, displacement of expansion joints, temperature, displacement of pier and anchorage, and relative displacement between the superstructure and substructure.
- Unscheduled or extraordinary inspections are made after unusual events and when required by the results of the regular or detailed inspections. The bridges are in-

strumented to monitor responses to abnormal conditions such as earthquakes and strong winds.

On the HSBA bridges, built-in travellers, lifts, gantries, and catwalks are provided, as shown in Figure 31, to facilitate close-up inspection and maintenance. Although some new bridges in the United States are now incorporating equipment to facilitate inspection, most older bridges lack this capability. HSBA also includes features to facilitate component replacement such as the hanger connection shown in Figure 32. HSBA, in cooperation with the Japan Construction Methods and Machinery Research Institute, has developed the repair robot as depicted in Figure 33. The robot is equipped with a work-head assembly, magnetic wheels, and TV cameras. The robot is designed to travel over bolted steel surfaces of structures. Potential applications are inspection and minor maintenance of the steel towers on the HSBA bridges.

For assessment of the load-carrying capacity of existing bridges, the current live load is compared first with the original design live load and potentially vulnerable areas are identified. If necessary, the assumed width of the uniform load is then reduced to the distance from curb to curb. Then, an overstress factor dependent on the ratio of dead to live load is allowed.

Discussions with PWRI and Professor Miki indicated that the Japanese do have a problem with fatigue cracking in many of their older steel structures. The primary problem is distortion fatigue due to secondary bending effects in the structures. There is a continuing need to develop retrofit strategies for these structures. The present day fatigue design specifications are very similar to those used in the United States. The Japanese believe that their current design practice is eliminating fatigue as a problem for their newer structures. This is very similar to current practice in the United States.

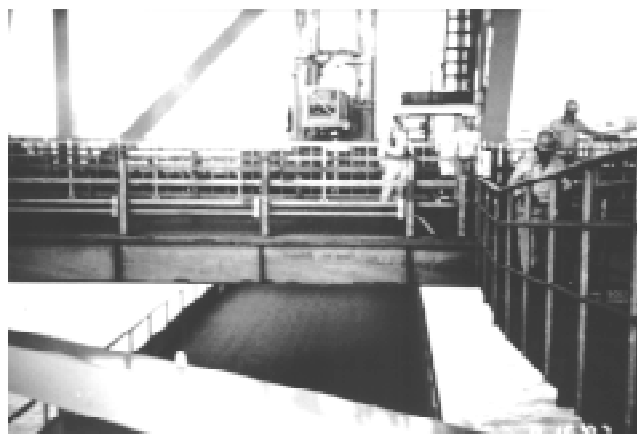

Figure 31. Inspection catwalks on the Akashi-Kaikyo Bridge.

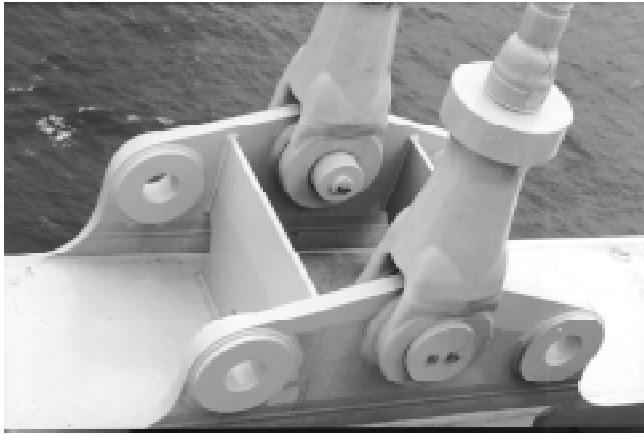

Figure 32. Hangar replacement attachment on the Akashi-Kaikyo Bridge.

In the area of rehabilitation, it was learned that temporary post-tensioning has been used on simple span bridges while the deck was removed. Alkali-silica reactivity has been observed in bridge piers that were 15 years old. The piers were sealed to prevent moisture ingress. Carbon fiber sheets are being used to strengthen bridge decks and piers.

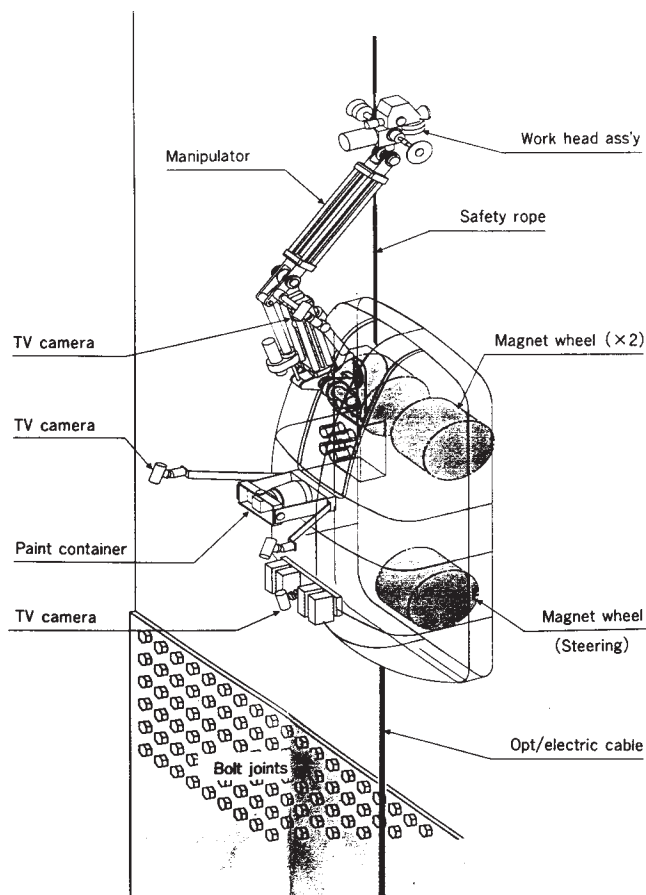

Figure 33. Repair robot (Diagram by HSBA).

## South Korea

Following collapse of the Sung-Su Grand Bridge, a “Special Law on Safety Management of Facilities” was passed. This law classifies bridge inspections as follows:

- Routine Inspection: four times per year for all bridges.
- Annual Inspection: once a year for major bridges. (First and second class bridges as defined by law.)
- Emergency Inspection: as needed following emergencies or natural disasters.
- Detailed Inspection: every 5 years for first class bridges which are at least 10 years old.

The new law requires that inspectors be trained and qualified.

KHC currently has the following inspection program:

- Regular Inspection: two times per year.
- Inspection of Structures Identified for Observation: once per month.
- Inspection at Any Time: as needed following emergencies or natural disasters.

KHC has 26 bridge inspectors, one in each province, and a 25-person analysis/evaluation group in the main office. Bridge inspection standards are based on the U.S. National Bridge Inspection Standards (NBIS) and the National Bridge Inventory (NBI). Equipment used in their inspections includes videocameras, half-cell potentiometers, ultrasonic testers, and photogrammetry. Special techniques include load tests and modal analysis. Special repair techniques have included external post-tensioning.

## Taiwan

The Taiwan Area National Freeway Bureau inspects its freeway bridges twice per year. Inspections are performed by in-house staff who have been trained by consultants. Bridges that are not part of the freeway are inspected every 2 years. The inspectors generally use visual observations to check deformations of bridge bearings, deformation or settlement of piers, excessive deflection of superstructures, crack widths, concrete spalling, and rust staining. Equipment used for access and non-destructive testing is similar to that used in the United States.

## Recommendations on Inspection and Rehabilitation Practices

Based on the above observations, the following topics are recommended for further evaluation and possible application in the United States:



- Greater emphasis on built-in access and utilities for bridge inspection and maintenance.
- A repair robot for use in inaccessible areas.

## **PROGRAMMING AND MANAGEMENT PRACTICES**

Very little was learned about programming and management practices. It seems that practices in the United States are more advanced than those in the three countries.

### **Japan**

None reported.

### **South Korea**

MOTC has a bridge management system for national highways developed for MS-Windows with a graphic user interface. The 5 regional construction and management offices and 19 highway maintenance and construction offices are connected through a computer network. The bridge management system offers the following features:

- Input/output of various bridge-related data.
- Input/output for inquiries about inspection results.
- Publication of status of bridges in the country.
- A decision-making system.
- Calculation of priority for repair, rehabilitation, or replacement.
- Selection of the method to repair or replace a damaged bridge.
- Calculation of costs for repair, rehabilitation, or replacement.

KHC reported that they have a system for small bridges and want to develop one for larger bridges. They have studied PONTIS for possible use as a model.

### **Taiwan**

The Taiwan Area National Freeway Bureau has had a bridge management system (BMS) since 1987. This system includes the basic inventory and design, construction, inspection, and maintenance information for the bridges. The system is being replaced with a newly developed BMS that uses a rating system for bridge defects. A defect in a bridge is rated for each of the following:

- Degree of severity of the defect.
- Extent of the defect over the area of the component.
- Importance of the defect on serviceability and safety.

The scoring is used to determine the priority for maintenance and budgeting.

## **OTHER INNOVATIONS**

### *Marketing of U.S. Engineering and Construction Services*

In the conduct of this scanning tour, the team met with members of the U.S. Commerce Department and other trade representatives. Benefits derived from these meetings were varied. One issue relates to the marketing of U.S. engineering and construction services abroad. The U.S. commerce representatives offered an opinion that there was a general lack of interest in their published announcements of opportunities for construction and engineering services. After further discussion, it became evident that the relationship between the engineering representative organizations and commerce department officials was minimal or non-existent. The vehicle for announcements of opportunities is the Commerce Department Journal which is not typically read by the engineering community. This is an issue best raised with ARTBA, AGC, and ACEC representatives. Certainly the industry and the commerce department have much to gain from improved relationships and better communications.

### *Visitors' Centers and Marketing Materials*

Many construction sites and private and public office sites had excellent visitors' centers and excellent informational materials for distribution. The informational materials are included in the lists in Appendix B. This practice is in contrast to U.S. practice. Investing in the positive marketing of engineered products has many tangible and intangible benefits. The public is better informed about the impacts to be expected, work progress, and justification for the project. They are also able to comprehend the positive long-term actions taken by public authorities. Private investments are encouraged to progress in tandem with the public investment. Young people are able to be brought onto active construction and manufacturing sites, given broad overviews into the technical world, and as a result, the imaginations of tomorrow's engineers and policy makers are stimulated. Professionals are able to more quickly ascertain the specifics of a project and to determine the technologies and practices that are worthy to be taken back to their own offices for implementation.

### *Miscellaneous Innovations*

The following miscellaneous innovations were also mentioned during the tour. However, detailed information was not provided.

- PWRI is developing a scour detection device using the principle of a fish finder.
- The Japanese have built two corrugated web plate bridges with a wave length of 1.2 m (3.9 ft) and a total amplitude of 200 to 300 mm (7.9 to 11.8 in.).
- In South Korea, the team learned that steel fiber reinforcement concrete is being studied as a means to reduce cracking in concrete bridge decks. Steel fibers are added at 0.50 percent by volume, but finishing problems have been experienced.
- KHC has used some instrumentation on bridges and seems to make extensive and effective use of intelligent transportation systems.
- KHC is planning to build a test road with two bridges. The test road will parallel an existing road and use regular highway traffic.

### Recommendations on Other Innovations

Based on the above observations, it is recommended that greater emphasis be placed on public relations programs for major projects.

## APPENDIX A AMPLIFYING QUESTIONS

### 1. INTRODUCTORY TOPICS

- 1.1 What is the organizational arrangement for bridge ownership, design, construction, maintenance, and funding?
- 1.2 What are the current major issues related to funding, design, construction, and maintenance?
- 1.3 What is your relative market share of steel versus concrete bridges. What controls this market share?
- 1.4 How do you decide where and when to build new bridges?

### 2. DESIGN STANDARDS, CODES AND SPECIFICATIONS

- 2.1 How are bridge design standards, codes, and specifications developed, implemented, and updated?
- 2.2 What design approach is currently used (service load, load factor, load resistance factor, limit state, or other)? What changes do you anticipate in the future?
- 2.3 What are the design provisions for vehicular load, overloads, earthquake, ship impact, thermal gradient, load combinations, scour, bridge deck replacement, environment requirements, aesthetics, and redundancy with fracture critical members?
- 2.4 To what extent are performance specifications used?

### 3. DESIGN AND CONSTRUCTION

- 3.1 What types of bridges, foundations, and construction methods are used? How are they selected?
- 3.2 To what extent is design automated and how is this implemented?
- 3.3 To what extent is design-build or design-build-operate used? What types of specifications are used? What are the results?
- 3.4 Do you consider user costs and public inconvenience in design and construction? If so, how?
- 3.5 Are alternate designs prepared and can contractors submit alternate designs?
- 3.6 What aspects of design and construction are standardized?
- 3.7 How is the intent of a design implemented in the construction process?
- 3.8 How are designers and contractors selected and paid? What incentives or penalties are provided to designers and contractors?
- 3.9 How much are innovation, prefabrication, and automation used in construction?
- 3.10 How are quality control and quality assurance of materials and construction processes implemented? Are in-place instrumentation systems used?
- 3.11 What warranties or guarantees are provided for materials and completed construction?

### 4. FABRICATION AND JOINING TECHNIQUES

- 4.1 How closely do designers, steel producers, and steel fabricators work together?
- 4.2 What recent developments in materials technology and cutting or drilling techniques have made your plate steel manufacturing processes successful?
- 4.3 What is your experience with corrosion resistant weathering steels and galvanized, metalized, or coated bridge steels?
- 4.4 What is your experience with fatigue and fracture of structural steels? What conclusions have you drawn from your experience?
- 4.5 How do you combine ease of erection and joining with the steel fabrication process?
- 4.6 What is current state of knowledge and practice regarding cable design, fabrication, erection, inspection, and corrosion protection?
- 4.7 What prestressing systems, strand sizes, corrosion protection systems for post tensioning, types of precast concrete joints, and external post-tensioning systems are you using? What has been your experience?
- 4.8 What types of bridge bearings, deck joints, and deck drainage systems are used?

## 5. BRIDGE DECK PROTECTION STRATEGIES

- 5.1 What types of bridge decks are used? What is the percentage of each?
- 5.2 What are the primary types and causes of bridge deck deterioration?
- 5.3 What are your bridge deck protection strategies, how are they chosen, and what is done to promote durability? How do different strategies compare in terms of implementation, performance, and cost.
- 5.4 What is the design life, expected life, and actual life of your bridge decks?
- 5.5 How is in-service bridge deck performance evaluated?

## 6. INSPECTION AND REHABILITATION

- 6.1 What types of formal bridge inspection programs are used?
- 6.2 How is the program implemented in terms of responsibility, staffing, training, qualifications of inspectors, data collection, quality control, inspection frequency, detail of inspection, and application of results?
- 6.3 How do you assess vulnerability of existing bridges to failure from earthquakes, scour, overload, vehicle and ship collision, steel details, and concrete details?
- 6.4 What tools and techniques are used to identify chloride penetration in concrete; corrosion and fatigue of structural steel, nonprestressed reinforcement, prestressing steel and stay cables; and scour?
- 6.5 What types of equipment are used for access, visual inspection in inaccessible areas, non-destructive testing, underwater inspection, and automated inspection (cameras, instrumentation, computers, fiber optics, and robotics)?
- 6.6 What means and methods are used to determine load carrying capacity of existing bridges?

## 7. PROGRAMMING AND MANAGEMENT

- 7.1 Do you have an established database of bridge type and condition?
- 7.2 What information do you collect and how is it used to manage bridges and set priorities for maintenance, improvements, and replacements of existing bridges?
- 7.3 How do you include information from bridge inspections and bridge maintenance programs into financial decisions and design standards and codes?
- 7.4 How do you decide whether to rehabilitate or replace a bridge or bridge deck?
- 7.5 What techniques are used in bridge rehabilitation for removal of existing materials, increasing load capacity, quality control and assurance, retrofitting of fatigue-sensitive details, treatment of lead-based paints, repair of scour, rapid bridge deck replacement, and replacement of welding with adhesives?

## 8. INNOVATION

- 8.1 What significant investments and advancements have been made in the last ten years to enhance the bridge design and construction industries?
- 8.2 How are innovative materials (high-strength steel, high-performance concrete, lightweight concrete, fiber-reinforced composite materials, fiber-reinforced concrete, high performance coatings, and geo-synthetics) introduced and used in bridge projects? Who promotes the development and utilization and who accepts responsibility?
- 8.3 To what extent are innovative materials being used to provide higher strength and improved durability?
- 8.4 How is quality control and performance of innovative materials and methods monitored? Are in-place instrumentation systems used?
- 8.5 What research do you recommend for safer, more durable bridges?
- 8.6 What recent experience, research, and retrofit has there been for cable-stay vibrations caused by wind and rain?

## APPENDIX B MATERIAL REVIEWED

This appendix contains a list of documents that were used in the preparation of this report.

### JAPAN

#### Honshu-Shikoku Bridge Authority

Honshu-Shikoku Bridges  
 Akashi-Kaikyo Bridge Engineering Note  
 Akashi-Kaikyo Bridge  
 Seto-Ohashi Bridges, Kojima-Sakaide Route in Honshu-Shikoku Bridges  
 Seto-Ohashi Bridge  
 Honshu-Shikoku Bridges, Kojima-Sakaide Route  
 Design of Shock-Absorbing Device of Akashi-Kaikyo Bridge for Ship Collision  
 Nishiseto Expressway (Onomichi-Imabari Route)  
 Nishiseto Expressway, Kurushima Bridges  
 Kurushima Bridges-Cable Works  
 Tatara Bridge  
 Boundary Layer Wind Tunnel Laboratory  
 Repair Robot (for High-Rise Structures)  
 Synonymous with Long-Span Bridge Technology  
 Tanaka, K., Sato, K., Watanabe, S., Arima, I., and Suenaga, K., "Development and Utilization of High Performance Concrete for the Construction of the Akashi-Kaikyo Bridge," *High Performance Concrete in Severe Environments*, Publication SP-140, American Concrete Institute, Detroit, 1993, pp 25-51.

**Japan Highway Public Corporation**

National Expressway Practices in Japan  
Development of Technology for Expressway Bridges

**Metropolitan Expressway Public Corporation**

Metropolitan Expressway 1996

**Nippon Steel Corporation**

Nippon Steel Kimitsu Works  
Japan's Steel Industry and Kimitsu Works  
Nippon Steel, Research & Engineering Center  
High Performance Steel in Japan, Presentation for FHWA,  
September 18, 1997  
Miki, C. and Homma, Koji, "Application of High Performance Steels in Bridge Structure."  
Corrosion Protection System for Cables

**Yokogawa Bridge Corporation**

Yokogawa Steel Bridges & Frames  
Computerized Assembly and Testing System (CATS)  
Torii, K., Kojakura, Y., and Takada, K., "Computerized Assembling Test System for Steel Bridges: CATS."  
Challenges to Civil and Mechanical Engineering in 2000 and Beyond, Conference June 2-5 1997, Wroclaw, Poland

**Sumitomo Metal Industries, Ltd.**

Weather-Act Method

**SOUTH KOREA****Ministry of Construction and Transportation**

Roads in Korea

**Korea Highway Corporation**

Korea Highway Corporation  
Highway Research Center  
Seo-Hae Grand Bridge

**Ssang Yong Engineering & Construction Co., Ltd.**

Kimp'o Grand Bridge

**TAIWAN****Taiwan Area National Freeway Bureau**

Annual Report 1996  
Taiwan Area National Expressway Engineering Bureau Introduction  
Hsichih-Wuku Viaducts Widening Project, Sun Yat-Sen Freeway  
Images of the Northern Taiwan Second Freeway  
Freeway Traffic Surveillance & Control System

**APPENDIX C ITINERARY****Japan**

September 14, 1997.	Team Review Meeting
September 15, 1997.	Meeting with Honshu-Shikoku Bridge Authority
September 16, 1997.	Site Visits to Akashi-Kaikyo Bridge and Kojima-Sakaide Route
September 17, 1997.	Site Visits to Kurushima and Tatara Bridges
September 18, 1997.	Nippon Steel Corporation
September 18, 1997.	Yokogawa Bridge Corporation
September 19, 1997.	Meeting with Public Works Research Institute, Japan Highway Public Corporation, and Metropolitan Expressway Public Corporation

**South Korea**

September 21, 1997.	Team Review Meeting
September 22, 1997.	Meeting with Korea Highway Corporation
September 22, 1997.	Site Visit to Seo-Hae Grand Bridge
September 23, 1997.	Site Visit to Kimp'o Grand Bridge and Youngjong Bridge
September 23, 1997.	Meeting with POSCO Manufacturing Corporation

**Taiwan**

September 25, 1997.	Site Visit to Kaohsiung Beltway, Chishan Branch, and Kao-Ping Bridge
September 26, 1997.	Meeting with Taiwan Area National Expressway Engineering Bureau

September 26, 1997.	Site Visit to Hsichih-Wuku Viaducts and Traffic Surveillance and Control Center
September 27, 1997.	Team Review Meeting

## APPENDIX D TEAM MEMBERS

The team consisted of representatives from U.S. federal, state, and private sector agencies. This appendix contains brief biographical information about each team member.

**Mr. Charles (Chuck) L. Chambers**, Team Co-Chairman, is a Senior Structural Engineer in the Office of Engineering, Bridge Division, FHWA, Washington, DC.

**Mr. James E. Siebels**, Team Co-Chairman, is the Chief Engineer for Design and Construction for the Colorado DOT located in Denver, Colorado.

**Mr. Ralph E. Anderson** is the Bureau Chief of Bridges and Structures for the Illinois DOT in Springfield, Illinois.

**Mr. John P. Formosa** is the Division Bridge Engineer for the New York Division of the FHWA in Albany, New York.

**Mr. John M. Hooks** is the team leader for the Structures Applications Team, Office of Technology Applications, FHWA in Washington, DC.

**Dr. John M. Kulicki** is President and Chief Engineer of Modjeski and Masters, Inc., of Harrisburg, Pennsylvania.

**Mr. Jerry L. Potter** is the State Structures Design Engineer for the Florida DOT in Tallahassee, Florida.

**Dr. Henry G. Russell** is an engineering consultant who specializes in concrete design, construction and research.

**Mr. James E. Sothen** is Director of Structures Division for the West Virginia Division of Highways located in Charleston, West Virginia.

**Mr. William J. Wright** is a research structural engineer in the Structures Division of the FHWA's Office of Engineering Research and Development, where he has worked for the last 8 years.

**Mr. George Y. Yamamoto** is a registered civil engineer working for the California DOT.

## APPENDIX E ACRONYMS

### Japanese Organizations

HSBA	Honshu-Shikoku Bridge Authority
JH	Japan Highway Public Corporation
JSCE	Japan Society of Civil Engineers
JIS	Japanese Industrial Standards
MEPC	Metropolitan Expressway Public Corporation
PWRI	Public Works Research Institute

### Korean Organizations

BPR	Bureau of Public Roads
MOCT	Ministry of Construction and Transportation
KHC	Korea Highway Corporation

### Taiwanese Organizations

MOTC	Ministry of Transportation and Communication
------	--

### U.S. Organizations

AAR	Association of American Railroads
AASHTO	American Association of State Highway and Transportation Officials
ACEC	American Consulting Engineers Council
AGC	Associated General Contractors
AISC	American Institute of Steel Construction
AISI	American Iron and Steel Institute
ARTBA	American Road and Transportation Builders' Association
ASBI	American Segmental Bridge Institute
ASTM	American Society for Testing and Materials
DOT	Department of Transportation
FHWA	Federal Highway Administration
FRA	Federal Railroad Administration
NCHRP	National Cooperative Highway Research Program
NSBA	National Steel Bridge Alliance
NSF	National Science Foundation
PCA	Portland Cement Association
PCI	Precast/Prestressed Concrete Institute
TRB	Transportation Research Board

### General Terminology

BMS	Bridge management system
CADD	Computer-aided design and drafting
CAM	Computer-aided manufacturing
CATS	Computerized assembly and testing system
GMAW	Gas-metal-arc-welding
HPS	High-performance steels
HSLA	High-strength, low alloy
LRFD	Load and Resistance Factor Design
NBIS	National Bridge Inspection Standards
NBI	National Bridge Inventory
NT\$	New Taiwan dollars
SAW	Submerged arc welding
SI	International system of units
TMCP	Thermo-mechanical control processing



APPENDIX F SELECTED FIGURE FROM CATS  
BROCHURE

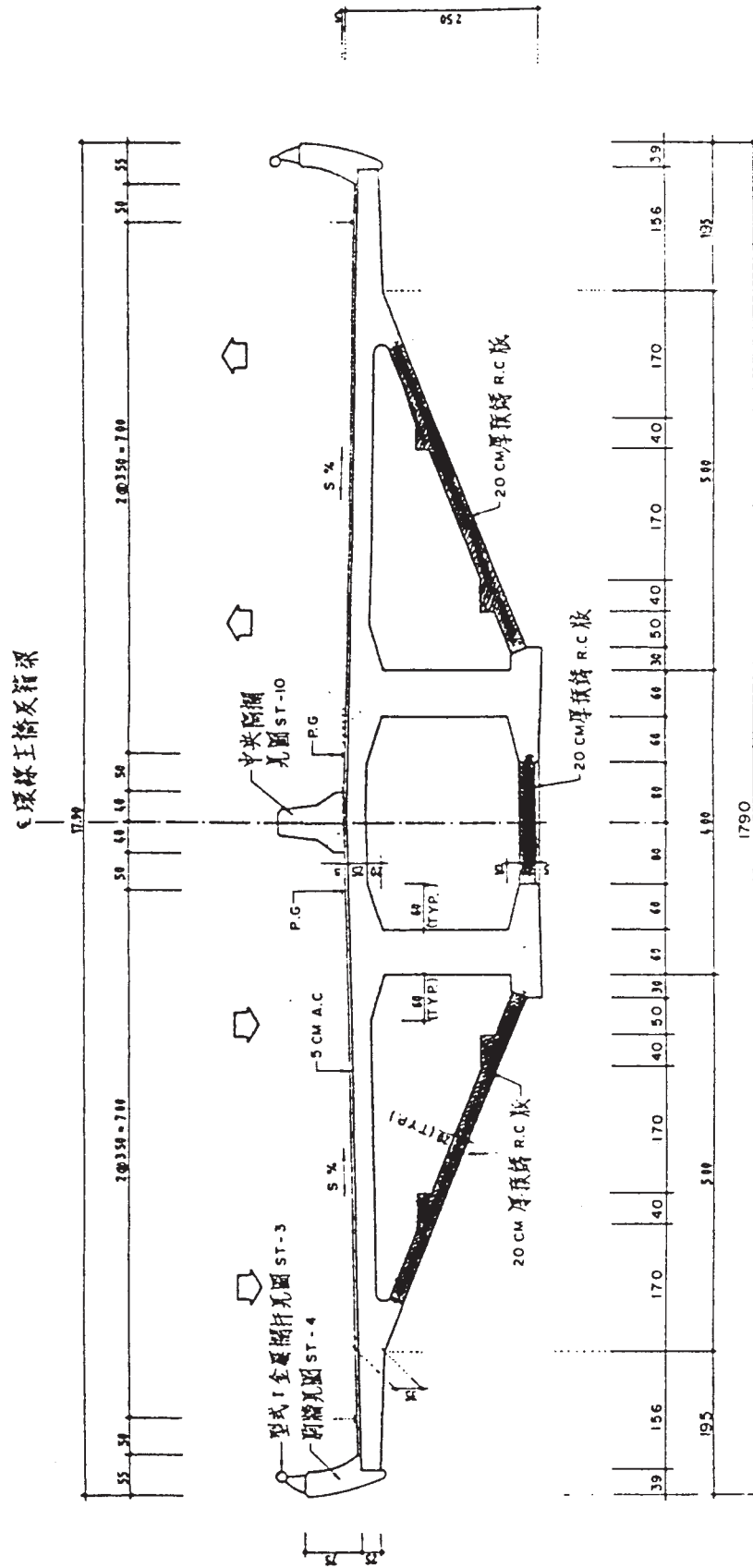

標準斷面圖

## Acknowledgments

The review team wishes to thank the hosting organizations and their staff in Japan, South Korea, and Taiwan for their gracious hospitality and for sharing their experience and time with the team members. In particular, the scanning team acknowledges the cooperation and assistance provided in Japan by Mr. Shoichi Saeki, Dr. Satoshi Kashima, Mr. Akira Mori, Mr. Yasuhito Kanisawa, Mr. Kunihisa Mori, Dr. Haruki Akiyama, Dr. Masahiko Yasuda, and Mr. Kazuyoshi Sakai of the Honshu-Shikoku Bridge Authority; Mr. M. Ohji, Mr. T. Nishi, Dr. Yukihiro Sumiyoshi, Mr. Shigenori Tsuru, Mr. Hachiro Sakata, Mr. K. Nishioka, Mr. Y. Yoshida, and Dr. Koji Homma of Nippon Steel Corporation; Mr. Kazuhiro Nishikawa of Public Works Research Institute; Professor Chitoshi Miki of the Tokyo Institute of Technology; Mr. Masatsugu Fukuda, Mr. Nobuyoshi Shibata, Mr. Yoshihito Kohata, Mr. Tohru Natori, and Mr. Akio Shirozu of Yokogawa Bridge Corporation; Mr. Hiroyuki Ikeda and Mr. Atsushi Homma of Japan Highway Public Corporation; and Mr. Jun Yamada and Mr. Kazuhiro Tsuno of Metropolitan Expressway Public Corporation. In South Korea, the team acknowledges Mr. In-Hee Nam of

the Ministry of Construction and Transportation and Mr. Jung-Tae Park, Dr. Sung Kon Kim, Mr. Jae-Shik Choi, Mr. Kyo Seo Wong, Mr. Sung Soon Ahn, and Mr. Woon-Phil Chung of Korea Highway Corporation. In Taiwan, the team acknowledges Dr. Wen-Lon Cheng, Mr. Nuan-Hsuan Ho, Mr. Song-Maw Hong, Mr. Wen-Chih Fang, and Mr. Chun Yat Hsu of the Ministry of Transportation and Communications.

The team members thank the sponsoring organizations for providing the opportunity to participate in this review. The NCHRP program officer was Edward T. Harrigan. Prior to the trip, input was provided by James D. Cooper of FHWA, Arun Shirole of the National Steel Bridge Alliance, and Man Chung Tang of DRC Consultants, Inc. The visit in Japan was greatly facilitated by previous relationships established by James D. Cooper of FHWA. The sponsors also thank American Trade Initiatives, Inc., for organizing the tour, providing the travel arrangements, and coordinating other activities. In particular, the services of Alexandra Doumani, Joseph N. Conn, and John O'Neill are appreciated.

Photographs and figures for the report were provided by the hosting organizations and team members. Their willingness to contribute to the report is acknowledged.

These **Digests** are issued in order to increase awareness of research results emanating from projects in the CRP. Persons wanting to pursue the project subject matter in greater depth should contact the Cooperative Research Programs Staff, Transportation Research Board, 2101 Constitution Ave., NW, Washington, DC 20418.

**TRANSPORTATION RESEARCH BOARD**  
National Research Council  
2101 Constitution Avenue, NW  
Washington, DC 20418

NON-PROFIT ORG.  
U.S. POSTAGE  
PAID  
WASHINGTON, DC  
PERMIT NO. 8970